



2017



ACCESSORI PER ORNITOLOGIA E ANIMALI

Accessories for ornithology and animals
Accesorios por ornitología y animales
Accessoires pour l'ornithologie et animaux



dal 1980



STORIA DELL'AZIENDA

Partner affidabile con oltre 35 anni di esperienza. La 2GR nasce nel 1980 come azienda produttrice di stampi per materie plastiche, per conto terzi.

Nel 1985 parallelamente all'attività di progettazione e costruzioni stampi, nasce la linea di prodotti per l'ornitologia che la 2GR inizia a produrre e commercializzare in proprio.

Fin da subito gli articoli 2GR spiccarono per qualità e facilità di montaggio e utilizzo, ma la scelta che si rivelò vincente, fu la ricerca di materiali assolutamente NON tossici.

Le esigenze di mercato e la creatività dello staff tecnico consente di ampliare ed arricchire la gamma dei prodotti; il continuo confronto con gli allevatori ci consente un'attenzione progettuale e produttiva costante. Oggi la 2GR è presente in tanti mercati del mondo con oltre 370 prodotti per l'ornitologia, cane, gatto, tartarughe e criceti per il massimo confort dei nostri piccoli amici.

THE HISTORY OF THE FACTORY

Reliable partner for over 35 years.

The 2GR was born on the 1980 as a factory producing moulds for plastic materials on behalf of a third party. In the 1985, together with the moulds' planning and producing activity, the 2GR creates its own ornitology range of products. The 2GR pays attention in choosing non toxic materials, high quality finishing, easy installation and use.

The market needs and the staff's creativity allow 2GR to enrich its range of products; the constant dialogue with breeders gives 2GR the possibility to pay attention to project making and constant production.

Nowadays, 2GR is present in many markets around the world with over 370 products for ornitology, cats, dogs, turtle and hamsters and the maximum confort for our little friends.

HISTORIA DE LA EMPRESA

Un socio fiable mas 35 años.

2GR nace en el año 1980 como empresa especializada en la fabricación a terceros de modelos para inyección de materia plastica.

En 1985, palalelamente a la actividad de proyectar y construir modelos, nace una linea de productos para la ornitologia. La empresa 2GR comienza a producir y comercializar productos desde su propia estructura, utilizando materiales no tóxicos, acabados de calidad, praticos y faciles de montar y utilizar.

Con la exigencia del mercado y la creatividad del equipo técnico logramos ampliar y enriquecer la gama de productos, así como la continua relación con los criadores logra que exista una atención y tension proyectiva y productiva constante.

Al día de hoy, la empresa 2GR esta presente en muchos y diferentes mercados del mundo con mas de 370 productos especializados para ornitologia, perros, gatos, tortugas y roedores con el fin de ofrecer el maximo confort a nuestros pequeños amigos.

HISTOIRE DE LA SOCIÉTÉ

Partenaire fiable avec plus de 35 années d'expérience.

2GR a été fondée en 1980 en tant que producteur de moules pour matériaux plastiques pour des tiers.

En 1985, en parallèle à la conception et la fabrication de moules, vient la ligne de produits pour l'ornithologie que 2GR commence à produire et à commercialiser en propre. La gamme de produits comprend une large gamme d'accessoires pour les oiseaux, comme des abreuvoirs, des mangeoires, des accessoires de transport, des baignoires et des nids; ainsi que des produits pour les petits animaux de compagnie comme les chiens et les chats, les tortues et les rongeurs, tels que des bols, des accessoires de transport, de la litière, des vivariums pour tortues et des cages pour hamsters. Depuis le début, les articles 2GR ont été appréciés pour leur qualité et leur facilité d'installation et d'utilisation, mais le choix qui a fait ses preuves a été la recherche de matériaux absolument non toxiques, une grande attention aux réglementations en vigueur concernant le transport des animaux, ce qui a amené 2GR à être le premier fabricant de produits de transport en plastique pour les oiseaux. Les exigences du marché et la créativité de l'équipe technique permettent d'élargir et d'enrichir la gamme de produits et le contact permanent avec les éleveurs nous permet d'assurer une attention constante dans la conception et la production. Aujourd'hui 2GR est présent sur de nombreux marchés dans le monde avec plus de 370 produits pour l'ornithologie, les chiens, les chats, les tortues et les hamsters pour assurer le confort maximum de nos petits amis.

INDICE

index - índice - index



UCCELLI

birds - pájaros - oiseaux

Trasportino Transport Trasportin Cage de transport	4	Nidi Nests Nidos Nids	47
Beverini Drinkers Bevederos Fontaines	22	Gabbie Cages Jaulas Cages	51
Mangiatoie Feeders Comederos Mangeoires	31	Fondi Bottoms Fondos Fonds	69
Bagni Baths Bañeras Bains	45	Accessori Accessories Accesorios Accessoires	70



RODITORI & TARTARUGHE

rodents & turtles - roedores & tortugas - rongeurs & tortues

Maisonette Maisonette Mansion Cage pour rongeurs	75	Sifoni Siphons Bebederos Abreuvoir pour rongeurs	81
Tartarughiere Turtles tanks Tortugueras Cage pour tortues	78	Accessori Accessories Accesorios Accessoires	83



CANI & GATTI

dogs & cats - perros & gatos - chiens & chats

Trasportini
Transport
Trasportin
Cages de transport

85

Lettiere
Litters
Lettieras
Litières

87

Ciotole
Bowls
Comederos
Bols

88

TINO



TUTTI I NOSTRI ARTICOLI DA TRASPORTO RISPETTANO LE NUOVE NORMATIVE

+



+ LEGGERO + ECONOMICO
SENZA INTERNO ESTRAIBILE



Art. 235

— cm. 38 x 39 x 18h
Tino Economy senza interno estraibile
Tino Economy without internal grey case
Tino Economy sin caja interna gris
Tino Economy sans caisse interne grise

**TINO
ECONOMY**





Art. 207

— cm. 38 x 39 x 3h
Coperchio con maniglia
Lid with handle
Tapa con asa
Couvercle avec poignée



CON INTERNO ESTRAIBILE



Art. 200

— cm. 38 x 39 x 18h
Trasportino con griglia fissa e mangiatoia esterna
Transport cage with fixed grill and external feeder
Trasportin con reja fija y comederos externos
Cage de transport avec grille fixe et mangeoires extérieures



Art. 250

Interno completo dell'Art. 200
Interior complete of Art. 200
Interior completo para Art. 200
Intérieur complet pour Art. 200





Art. 201

— cm. 38 x 39 x 18h

Trasportino con griglia fissa e mangiatoia interna

Transport cage with fixed grill and internal feeder

Trasportin con reja fija y comederos internos

Cage de transport avec grille fixe et mangeoires internes

TINO



8 033844 762447

Art. 251

Interno completo dell'Art. 201

Interior complete of Art. 201

Interior completo para Art. 201

Intérieur complet pour Art. 201



8 033844 763000

Art. 218

Scatola esterna del Tino

Tino 's external case

Caja externa de Tino

Caisse externe du Tino



8 033844 762584



Art. 202

— cm. 38 x 39 x 18h → 35h
Trasportino con griglia Telescopica
Transport cage with Telescopic grill
Trasportin con reja Telescópica
Cage de transport avec grille telescopique



8 033844 762454

IDONEO PER MOSTRE SCAMBIO

Art. 252

Interno completo dell'Art. 202
Interior complete of Art. 202
Interior completo para Art. 202
Interieur complet pour Art. 202



8 033844 763017

010 TRASPORTINO



MAXI
TINO



MANGIATOIE INTERNE



PORTA GRANDE

Art. 204

— cm. 66,8 x 34,3 x 21h
Trasportino per ondulati a 5 posti
Transport cage for budgerigar 5 spaces
Transportin para periquito australiano a 5 lugares



8 033844 762690



Art. 217

— cm. 66,8 x 34,3 x 2,5h
Coperchio per Maxi-Tino
Maxi-Tino's cover
Tapa para Maxi-Tino
Couvercle pour Maxi-Tino



MANGIATOIE ESTERNE

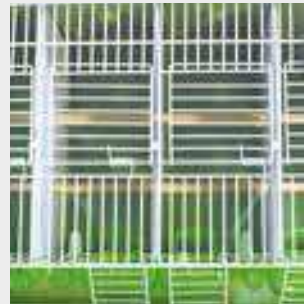

PORTA PICCOLA

Art. 205

— cm. 66,8 x 34,3 x 21h
Trasportino per soggetti di media taglia, 5 posti
Transport cage for medium sizes bird, 5 spaces
Transportin para parajos de tamaños mediano, 5 lugares
Cage de Transport pour oiseaux de moyenne taille, avec 5 lieux



RETRO CHIUSO



Art. 233

— cm. 66,8 x 34,3 x 21h
Trasportino per trasporto collettivo
Collective transport cage
Transportin para el transporte colectivo
Cage pour le transport collectif



12 TRASPORTINO

+



**TRASPORTO
SINGOLO**

Single transport
Transporte singolo
Transport individuel

SECONDINO

Art. 220

— cm. 16 x 11,7 x 14,6h
Trasporto singolo per taglie piccole fino a 14 cm
Single transport cage for small size till 14 cm
Transporte unico para tallas pequeñas hasta 14 cm
Cage de transport pour petites tailles, jusqu'à 14 cm



TUTTI I NOSTRI ARTICOLI DA TRASPORTO RISPETTANO LE NUOVE NORMATIVE



Art. 203

— cm. 38 x 39 x 18h
Tino + n. 6 Secondino





Art. 234

— cm. 66,8 x 34,3 x 21h
Maxi Tino + n. 10 Secondini



Art. 239

cm. 66,8 x 34,3 x 21h
Maxi Tino vuoto con supporti
Maxi Tino empty with support
Maxi Tino vacio con soporte
Maxi Tino vide avec soutient



14 TRASPORTINO

VALIGIA



Art. 225

— cm. 66,8 x 21 x 36h
Valigia completa di 10 Secondini
Complete case with 10 Secondini
Maleta con 10 Secondini
Valise complet avec 10 Secondini



Art. 226

— cm. 66,8 x 21 x 36h
Valigia vuota
Empty case
Maleta vacia
Valise vide





**SECONDINO
MEDIO**

Secondino Medium-size
Secondino Mediano
Secondino Moyen



+



+



Art. 244

— cm. 20 x 11 x 14 h.
Trasportino singolo per taglie fino a 18 cm.
Single transport cage for medium size till 18 cm
Transporte singolo para talla media hasta 18 cm
Cage de transport pour tailles jusqu'à 18 cm



Art. 256

— cm. 37 x 22 x 43h
Valigia 6 posti
Case with 6 places
Maleta con 6 lugares
Valise avec 6 lieux



Art. 261

Valigia vuota con 6 posti
Empty case with 6 places
Maleta vacia con 6 lugares
Valise vide avec 6 lieux



Art. 265

Kit luci per valigia 6 posti
Light kit for 6 places case
Sistema de iluminacion para maleta con 6 lugares
Lumiere pour valise avec 6 lieux



Art. 276

Copertura x valigia 6 posti
Cover for 6 places case
Cobertura para maleta con 6 lugares
Couverture pour valise avec 6 lieux



16 TRASPORTINO

Art. 257

— cm. 48 x 22 x 43h
Valigia 8 posti
Case with 8 places
Maleta con 8 lugares
Valise avec 8 lieux



Art. 262

Valigia vuota 8 posti
Empty case with 8 places
Maleta vacia con 8 lugares
Valise vide avec 8 lieux



Art. 266

Kit luci per valigia 8 posti
Light kit for 8 places case
Sistema de iluminacion para maleta con 8 lugares
Lumiere pour valise 8 lieux



Art. 277

Copertura x valigia 8 posti
Cover for 8 places case
Cobertura para maleta con 8 lugares
Couverture pour valise avec 8 lieux



Art. 258

— cm. 71 x 22 x 43h
Valigia 12 posti
Case with 12 places
Maleta con 12 lugares
Valise avec 12 lieux



Art. 263

Valigia vuota 12 posti
Empty case with 12 places
Maleta vacia con 12 lugares
Valise vide avec 12 lieux



Art. 267

Kit luci per valigia 12 posti
Light kit for 12 places case
Sistema de iluminacion para maleta con 12 lugares
Lumiere pour valise 12 lieux



Art. 278

Copertura x valigia 12 posti
Cover for 12 places case
Cobertura para maleta con 12 lugares
Couverture pour valise avec 12 lieux





Art. 259

— cm. 71 x 22 x 62h
Valigia 18 posti
Case with 18 places
Maleta con 18 lugares
Valise avec 18 lieux



8 033844 763086



Art. 264

Valigia vuota 18 posti
Empty case with 18 places
Maleta vacia con 18 lugares
Valise vide avec 18 lieux



8 033844 763130

Art. 268

Kit luci per valigia 18 posti
Light kit for 18 places case
Sistema de iluminacion para maleta con 18 lugares
Lumiere pour valise 18 lieux



8 033844 763178



Art. 279

Copertura x valigia 18 posti
Cover for 18 places case
Cobertura para maleta con 18 lugares
Couverture pour valise avec 18 lieux



8 033844 763277

Art. 270

Kit luci universale
Universal light kit
Sistema de iluminacion universal
Lumiere universel



8 033844 763192

Art. 271

Accendisigari con cavo di mt.3
Lighter with 3 m. cable
Encendedor con cable de 3 m.
Briquet avec cable 3 mt.



8 033844 763208

18 TRASPORTINO



Art. 273

— cm. 78 x 48 x 113h
Carrello con 60 secondini medi
Trolley with 60 medium-size Secondini
Carrito con 60 Secondini medianos
Chariot avec 60 Secondini



Art. 273/A

— cm. 78 x 48 x 43h
Modulo superiore con 24 Secondini
Upper module with 24 Secondini
Modulo superior con 24 Secondini
Module supérieur avec 24 Secondini



Art. 273/B

— cm. 78 x 48 x 70h
Modulo inferiore con 36 Secondini
Lower module with 36 Secondini
Modulo inferior con 36 Secondini
Module basse avec 36 Secondini



Art. 273/C

— cm. 78 x 48 x 6h
Comp. trasformazione ruote removibili
Additional part for removable wheels
Componente para ruedas removable
Part supplémentaire pour roues amovibles



Art. 260

cm. 120 x 44 x 164h
Carrello con 160 secondini medi
Trolley with 160 medium-size Secondini
Carrito con 160 Secondini medianos
Chariot avec 160 Secondini

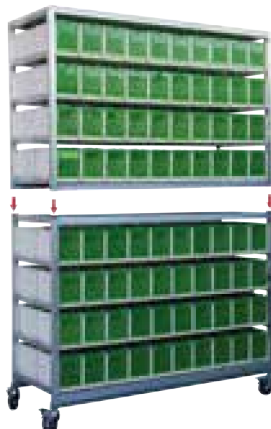

Art. 269

Kit luci x art.260
Light kit for art. 260
Sistema de iluminacion para art. 260
Lumiere pour art. 260



FORMATO DA DUE MODULI
MADE UP OF TWO MODULES
HECHO CON DOS MODULOS
FAIT AVEC DEUX MODULES





**SECONDINO
MAXI**



Art. 242

— cm. 31 x 11,5 x 16h
Trasportino singolo per taglie fino a 28 cm
Single transport cage for medium size till 28 cm
Transporte singolo para talla media hasta 28 cm
Cage de transport pour tailles jusqu'à 28 cm



RISPETTA LE NUOVE NORMATIVE



Art. 245

— cm. 66,8 x 34,3 x 21h
Maxi Tino + n. 5 Secondini Maxi



COMPONENTI

Art. 214

— cm. 10 x 5 x 4h
Mangiatoia rettangolare
Rectangular feeder
Comedero rectangular
Mangeoire rectangulaire



Art. 206

cc. 100
Beverino rettangolare
Rectangular drinker
Bebedero rectangular
Fontaine rectangulaire



8 033844 762553



8 033844 762478

Art. 248

cc. 50
Beverino/Mangiatoia per art. 242 e 244
Drinker/Feeder for art. 242 and 244
Bebedero/Comedero para art. 242 y 244
Fontaine/Mangeoire pour art. 242 et 244



8 033844 762973

Art. 247

Gancio per coperchio valigia art. 225
Hook for case's cover art. 225
Gancho para tapa maleta art. 225
Crochet pour couvercle de la valise art. 225



Art. 210

Gancio
Hook
Gancho
Crochet



8 033844 762966



8 033844 762515

Art. 216

— cm. 29
Posatoio per Art. 200-201-202
Perch for Art. 200-201-202
Posaderos para Art. 200-201-202
Perchoir pour Art. 200-201-202



Art. 249

— cm. 35,5
Posatoio per Art. 235
Perch for Art. 235
Posaderos para Art. 235
Perchoir pour Art. 235



8 033844 762577



8 033844 762980



Art. 215

Parete estraibile per Tino
Tino's removable wall
Pared extraíble para Tino
Amovible cloison pour Tino



8 033844 762560

Art. 227

Parete estraibile per Maxi-Tino
Maxi-Tino's removable wall
Pared extraíble para Maxi-Tino
Amovible cloison pour Maxi-Tino



8 033844 762751

Art. 236

Divisoria per Tino Economy
Tino Economy's dividing wall
Divisoria para Tino Economy
Cloison pour Tino Economy



8 033844 762850

Art. 209

Divisoria per Tino
Tino's Dividing wall
Divisoria para Tino
Cloison pour Tino



8 033844 762508

Art. 228/C

Divisoria per Maxi-Tino
Maxi-Tino's dividing wall
Divisoria para Maxi-Tino
Cloison pour Maxi-Tino



8 033844 762775

PER MAXI TINO SENZA
POSATOI

Art. 228/A

Divisoria per Maxi-Tino
Maxi-Tino's dividing wall
Divisoria para Maxi-Tino
Cloison pour Maxi-Tino



8 033844 762768

Art. 237

Supporti per Secondino
Supports for Secondino
Soportes para Secondino
Soutien pour Secondino



6 PCS.



4 PCS.

Art. 208

Ruote
Wheels
Ruedas
Roues



8 033844 762492



8 033844 762867

Art. 238

Griglia per Art. 235
Grill for Art. 235
Reja para Art. 235
Grille pour Art. 235



Art. 211

Griglia per Art. 200
Grill for Art. 200
Reja para Art. 200
Grille pour Art. 200



Art. 212

Griglia per Art. 201
Grill for Art. 201
Reja para Art. 201
Grille pour Art. 201

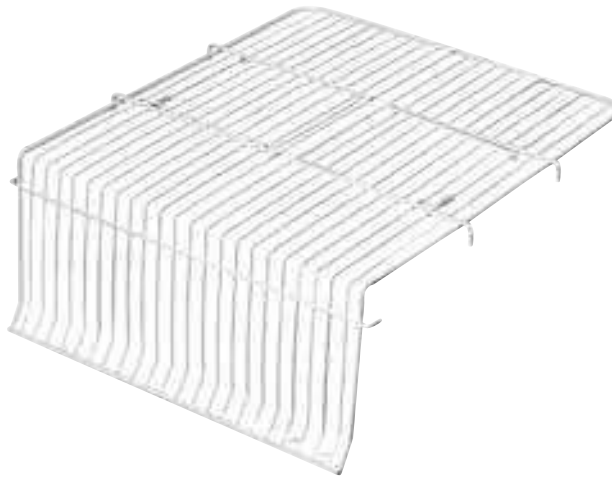

Art. 213

Griglia per Art. 202
Grill for Art. 202
Reja para Art. 202
Grille pour Art. 202





Art. 229

Griglia per art.204
Grill for art. 204
Reja para art. 204
Grille pour art. 204



Art. 230

Griglia per art.205
Grill for art. 205
Reja para art. 205
Grille pour art. 205



SERIE CON BORDO



Art. 240

cc. 20
Beverino Dino
Dino drinker
Bebedero Dino
Fontaine Dino

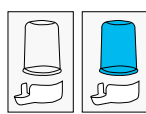

Art. 221

cc. 30
Beverino Secondino
Secondino drinker
Bebedero Secondino
Fontaine Secondino

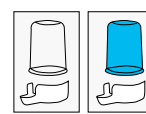

Art. 146

cc. 40
Beverino per medicinali
Medicine dispenser
Bebedero para medicamentos
Fontaine pour médicaments

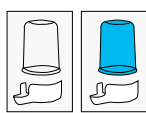

Art. 158

cc. 80
Beverino corto lusso
Short luxury drinker
Bebedero corto lujo
Fontaine court luxe

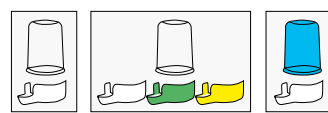

Art. 274

cc. 80
Sifone Aosta corto
Aosta short siphon
Bebedero corto Aosta
Fontaine court Aosta

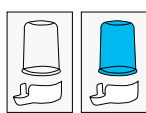

Art. 128

cc. 110
Beverino lungo lusso
Long luxury siphon
Bebedero largo lujo
Fontaine long luxe

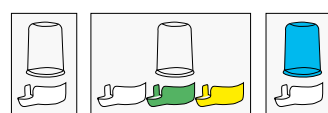



**SERIE
CON
BORDO**



Art. 284

cc. 110
Sifone Aosta lungo
Aosta long siphon
Bebedero Aosta largo
Fontaine long Aosta

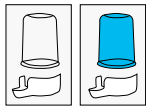

Art. 222

cc. 110
Sifone universale
Siphon universal
Bebedero universal
Fontaine Universel



Art. 131

cc. 120
Sifone Marta
Marta siphon
Bebedero Marta
Fontaine Marta

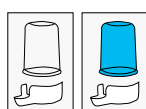

Art. 275

cc. 200
Sifone Ferrara
Ferrara siphon
Bebedero Ferrara
Fontaine Ferrara

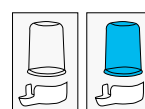

Art. 285

cc. 400
Sifone Livorno
Livorno siphon
Bebedero Livorno
Fontaine Livorno

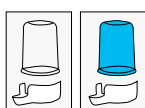

**SERIE
SENZA
BORDO**



Art. 018/F

cc. 75
Beverino corto fumè
Short brown siphon
Bebedero corto fumé
Fontaine court fumé



Art. 018

cc. 75
Beverino corto
Short siphon
Bebedero corto
Fontaine court

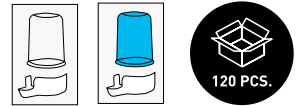

Art. 038

cc. 85
Sifone lungo
Long siphon
Bebedero largo
Fontaine long



Art. 040

cc. 70
Sifone corto mix
Short siphon mix
Bebedero corto mix
Fontaine court mix

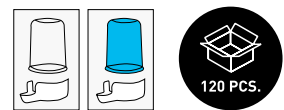

Art. 040/F

cc. 70
Sifone corto mix fumè
Short brown siphon mix
Bebedero corto mix fumé
Fontaine court mix fumé



Art. 030

cc. 90
Sifone lungo mix
Long siphon mix
Bebedero largo mix
Fontaine long mix

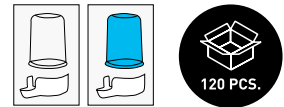



**SERIE
SENZA
BORDO**



Art. 134

cc. 200
Sifone Firenze lusso
Firenze luxury siphon
Bebedero Florencia lujo
Fontaine Florence luxe

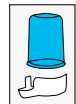
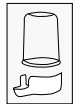

Art. 184

cc. 200
Sifone Leo
Leo siphon
Bebedero Leo
Fontaine Leo

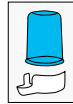
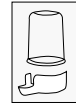

Art. 034

cc. 200
Sifone Firenze
Firenze siphon
Bebedero Florencia
Fontaine Florence

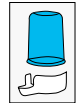
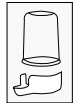

Art. 034/F

cc. 200
Sifone Firenze fumè
Firenze brown siphon
Bebedero Florencia fumè
Fontaine Florence fumè



Art. 157

cc. 280
Beverino Correggio
Correggio drinker
Bebedero Correggio
Fontaine Correggio

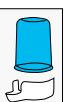
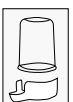

Art. 068

cc. 280
Sifone Reggio
Reggio siphon
Bebedero Reggio
Fontaine Reggio

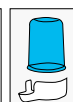
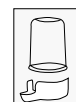

**SERIE
SENZA
BORDO**



Art. 060/A

cc. 400
Sifone Lucca con anello
Lucca siphon with ring
Bebedero Lucca con anilla
Fontaine Lucca avec anneau



8 033844 760726

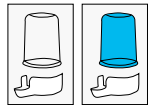

Art. 060

cc. 400
Sifone Lucca
Lucca siphon
Bebedero Lucca
Fontaine Lucca



8 033844 760719

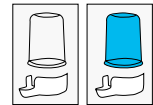

Art. 087

cc. 80
Sifone banana
Banana-shaped siphon
Bebedero banana
Fontaine banane



8 033844 760986

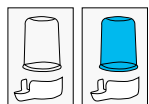

Art. 076

cc. 400
Sifone Roma
Roma siphon
Bebedero Roma
Fontaine Roma



8 033844 760870

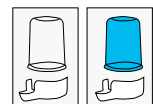



Art. 090/B

cc. 40
Sifone weekend basso
Weekend short siphon
Bebedero bajo weekend
Fontaine Weekend Basse



8 033844 760085



24 PCS.



Art. 090

cc. 70
Sifone weekend
Weekend siphon
Bebedero weekend
Fontaine Weekend



8 033844 761013



24 PCS.



Art. 090/A

cc. 90
Sifone weekend alto
High weekend siphon
Bebedero weekend alto
Fontaine Weekend Haut



24 PCS.



8 033844 761020

Art. 092

cc. 280
Sifone weekend Reggio
Reggio weekend siphon
Bebedero weekend Reggio
Fontaine weekend Reggio



8 033844 761044



12 PCS.



Art. 093

cc. 400
Sifone weekend Lucca
Lucca weekend siphon
Bebedero weekend Lucca
Fontaine weekend Lucca



8 033844 761051



12 PCS.



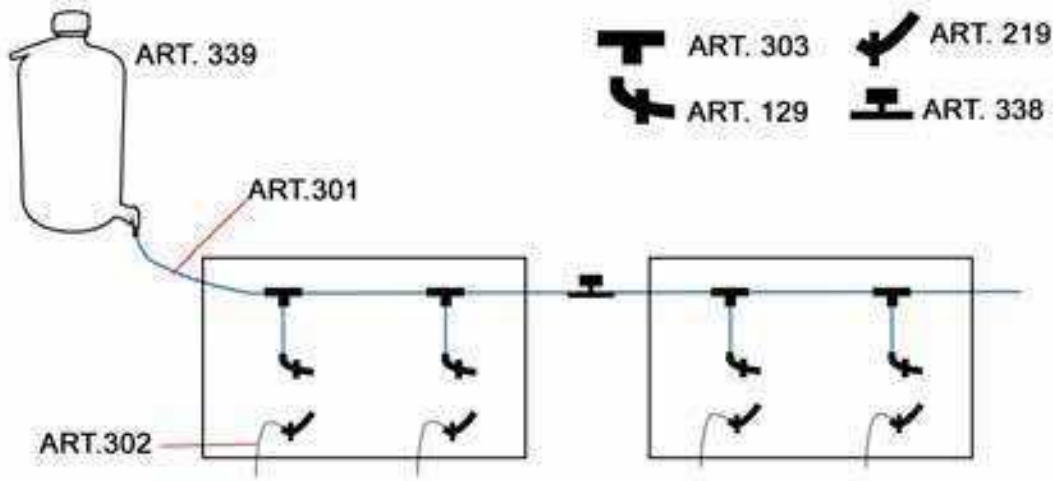

Art. 129

Erogatore magic
Magic dispenser
Dispensador magic
Distributeur Magique



8 033844 761495



Art. 219

— cm. 6 x 2 x 2h
Salva-goccia per Art. 129
Drop-saver for Art. 129
Salva-gota para Art. 129
Salve-goutte pour Art. 129



8 033844 762737



12 PCS.



12 PCS.

Art. 301

Tubo diam. int. 5 per art. 129
Tube diameter int. 5 for art. 129
Tubo diámetro int. 5 para art. 129
Tube diametre int. 5 pour art. 129



8 033844 763383



Ø INT. MM. 8



8 033844 763390



50 MT.



25 MT.

Art. 303

Raccordo a "T" per tubo art. 301
"T" Connection for tube art. 301
Conector "T" para tubo art. 301
Raccord "T" pour tube art. 301



8 033844 763406



50 PCS.

Art. 338

Rubinetto per tubo art. 301
Tap for tube art. 301
Grifo para tubo art. 301
Robinet pour tube art. 301



8 033844 764090



50 PCS.

Art. 339

Serbatoio per impianto a goccia
Tank for drop system
Tanque para sistema de gota
Réservoir pour système goutte



lt. 10



8 033844 764106



1 PCS.



Art. 310

cc. 500 - cm. 9 x 9 x 10h
Beverino Capri
Capri dispenser
Bebedero Capri
Fontaine Capri

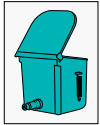

Art. 170

cc. 500 - cm. 9 x 9 x 10h
Beverino Aves
Aves dispenser
Bebedero Aves
Fontaine Aves



Art. 311

cc. 1000 - cm. 9 x 9 x 18h
Beverino Giglio
Giglio dispenser
Bebedero Giglio
Fontaine Giglio

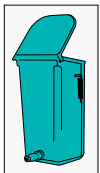

Art. 171

cc. 1000 - cm. 9 x 9 x 18h
Beverino Aves
Aves dispenser
Bebedero Aves
Fontaine Aves



Art. 130

cc. 130
Beverino magic
Magic drinker
Bebedero magic
Fontaine magique



Art. 321

cc. 400
Sifone Bari
Bari siphon
Bebedero Bari
Fontaine Bari



8 033844 763581



Art. 066

cc. 400
Sifone Napoli
Napoli siphon
Bebedero Napoles
Fontaine Napoli



8 033844 760771



REGOLABILE

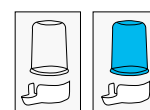

Art. 066/B

cc. 280
Sifone Napoli basso
Short Napoli siphon
Bebedero Napoles bajo
Fontaine Napoli court



8 033844 764045

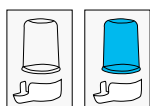

Art. 065

cc. 200
Sifone mang. pappagalli
Feeder and siphon for parrot
Comodero bebedero papagayo
Siphon mangeoire perroquet



8 033844 760764



Art. 253

— cm. 9 x 9 x 6,5h
Mangiatoia "Ara" piccola
"Ara" small Feeder
Comodero "Ara" pequeño
Mangeoire "Ara" petit



8 033844 763024



Art. 254

— cm. 12 x 12 x 6,5h
Mangiatoia "Ara" media
"Ara" medium Feeder
Comodero "Ara" mediano
Mangeoire "Ara" moyen



8 033844 763031





Art. 058

cc. 1500
Abbeveratoio per polli
Water dispenser for chicken
Abrevadero para pollitos

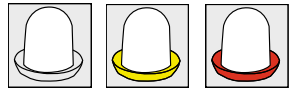

Art. 186

— cm. 8 x 5
Porta
Door
Puerta
Porte



**MOLLA NON INCLUSA
SPRING NOT INCLUDED**

Art. 185

— cm. 7,5 x 5 x 8h
Mangiatoia Hasselt
Hasselt feeder
Comodero Hasselt
Mangeoire Hasselt



Art. 335

— cm. 7,3 x 8 x 7,5h
Mangiatoia Amsterdam
Amsterdam Feeder
Comedero Amsterdam
Mangeoire Amsterdam



Art. 199

— cm. 7,5 x 5 x 8h
Mangiatoia Piacenza
Piacenza Feeder
Comodero Piacenza
Mangeoire Piacenza



Art. 017

— cm. 7 x 4 x 7h
Mangiatoia Napoli
Napoli feeder
Comedero Napoles
Mangeoire Napoli



34 MANGIATOIE

Art. 147

— cm. 8 x 4,5 x 7,5h
Mangiatoia "lusso"
"Lusso" feeder
Comedero "Lujo"
Mangeoire Luxe



8 033844 761662



50 PCS.

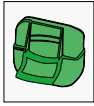
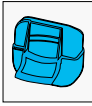
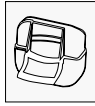

Art. 160

— cm. 8 x 4,5 x 7,5h
Mangiatoia Milano
Milano feeder
Comedero Milano
Mangeoire Milano



8 033844 761792



50 PCS.

Art. 024

— cm. 7 x 4 x 8h
Mangiatoia esterna
External feeder
Comedero externo
Mangeoire Exterieur



8 033844 760320



96 PCS.

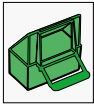
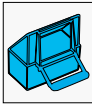
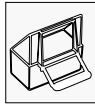

Art. 232

— cm. 7 x 4 x 8h
Mangiatoia interna con ganci
Internal feeder with hooks
Comedero interno con ganchos
Mangeoire interieur avec crochet



8 033844 762812

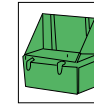
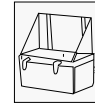

96 PCS.

Art. 161

— cm. 8 x 4,5 x 7,5h
Mangiatoia interna Madrid
Madrid internal feeder
Comedero interno Madrid
Mangeoire interieur Madrid



8 033844 761808



50 PCS.





Art. 103

— cm. 6,5 x 4 x 7,5h
Mangiatoia Spagna 2000
Spagna 2000 feeder
Comedero España 2000
Mangeoire Espagne 2000



8 033844 761174



Art. 105

— cm. 6,5 x 4 x 7,5h
Mangiatoia Italia 2000
Italia 2000 feeder
Comedero Italia 2000
Mangeoire Italia 2000



8 033844 761198



Art. 028

— cm. 6 x 4 x 5,3h
Mangiatoia mezzaluna
Half moon shaped feeder
Comedero media luna
Mangeoire demi-lune



Art. 336

— cm. 6,4 x 4,5
Coperchio per mangiatoia mezzaluna
Cover for half moon shaped feeder
Tapa para comedero media luna
Couvercle pour mangeoire demi-lune



Art. 035

— cm. 6 x 4 x 5,3h
Mangiatoia mezzaluna ganci
Half moon shaped feeder with hooks
Comedero media luna con gancho
Mangeoire demi-lune avec crochet



8 033844 760382



8 033844 763888



8 033844 760450



Art. 012

— cm. 6 x 3,4 x 3,2h
Mangiatoia att. dir. piccola
Small feeder with direct connection
Comedero pequeño enganchedirecto
Petit mangeoire connexion directe



8 033844 760146



Art. 013

— cm. 6 x 4 x 4,4h
Mangiatoia attacco diretto grande
Big feeder with direct connection
Comedero grande enganche directo
Mangeoire grand connexion directe



8 033844 760153



36 MANGIATOIE

LA NUOVA MANGIATOIA ANTISPRECO RIVOLUZIONARIA - THE NEW REVOLUTIONARY NO-WASTE FEEDER
EL NUEVO COMEROREVOLUCIONARIOANTI- DERROCE - LENOUEAUREVOLUTIONNAIREMANGEOIREANTI-GASPILLAGE

Art. 323

- cm. 8 x 10 x 13,5h
Mangiatoia Eclissi
Eclipse feeder
Comedero Eclipse
Mangeoire Eclipse



kg. 0,240

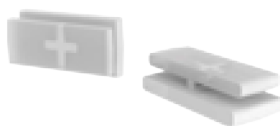

ADATTATORE 323/G GIA' INCLUSO
ADAPTER 323/G INCLUDED
ADAPTADOR 323/G INCLUIDO
ADAPTATEUR 323/G INCLUS

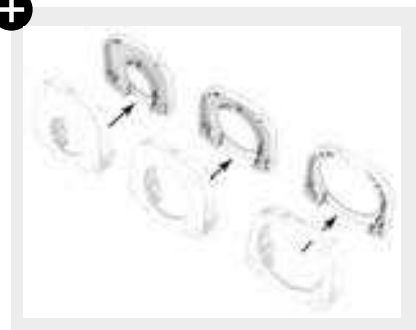
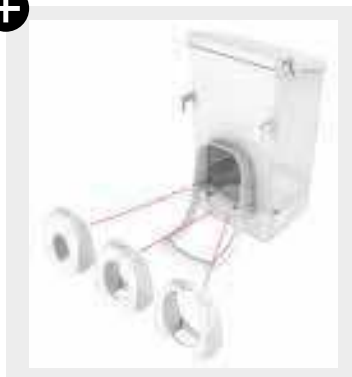

SENZAPORTINA



PORTINAMONTATAALCONTRARIO



PORTINAPIEGATA



Art. 323/G

Adattatore universale per Mangiatoia Eclissi
Universal adapter for Eclipse Feeder
Adaptador universal para comedero Eclipse
Adaptateur universel pour mangeoire Eclipse

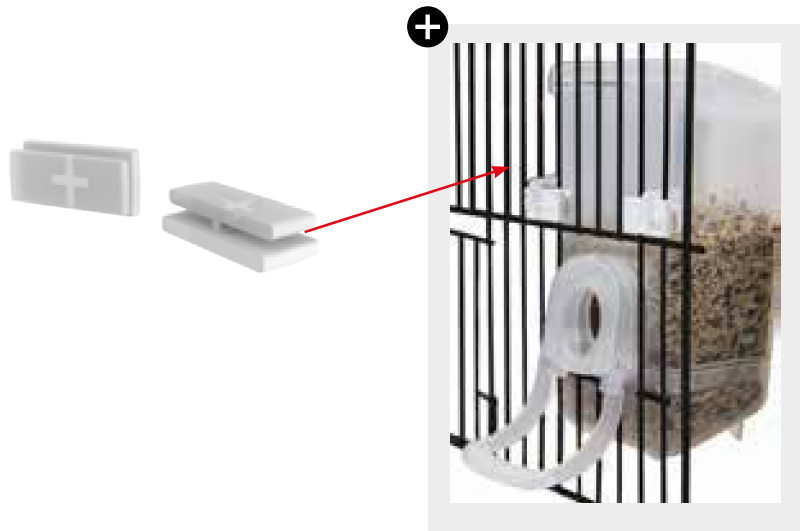

Art. 323/I

Supporti per attacco interno gabbia per Mangiatoia Eclissi
Cage's internal attachment for Eclipse Feeder
Suporte para ataque interno jaula para comedero Eclipse
Soutien d'attaque a l'interieure cage pour mangeoire Eclipse



Art. 117

- cm. 14 x 10 x 18h
Mangiatoia economy plus
Economy plus feeder
Comedero economy plus
Mangeoire economique plus



8 033844 761334



kg. 1



Art. 169

- cm. 10 x 9 x 15,5h
Mangiatoia economy Diamant
Diamant economy feeder
Comedero economy Diamant
Mangeoire economique Diamant



8 033844 761969



kg. 0,250



Art. 155

- cm. 14 x 10 x 21h
Mangiatoia economy dispenser
Economy feeder dispenser
Comedero economy dispenser
Mangeoire economique dispenser



8 033844 761747



kg. 1



Art. 115

- cm. 8 x 7 x 16h
Mangiatoia economy
Economy feeder
Comedero economy
Mangeoire economique



8 033844 761297



Ø24

kg. 0,250



Art. 115/A

- cm. 8 x 7 x 16h
Mangiatoia economy
Economy feeder
Comedero economy
Mangeoire economique



8 033844 761303



Ø28

kg. 0,250



Art. 116

- cm. 8 x 7 x 16h
Mangiatoia economy
Economy feeder
Comedero economy
Mangeoire economique



8 033844 761310



Ø24

kg. 0,250



Art. 116/A

- cm. 8 x 7 x 16h
Mangiatoia economy
Economy feeder
Comedero economy
Mangeoire economique



8 033844 761327



Ø28

kg. 0,250





Art. 173

— cm. 10,5 x 5,5 x 5h
Mangiatoia Dalia
Dalia feeder
Comedero Dalia
Mangeoire Dalia



8 033844 762003



40 PCS.



Art. 172

— cm. 10,5 x 5,5 x 5h
Mangiatoia Ines
Ines feeder
Comedero Ines
Mangeoire Ines



8 033844 761990



40 PCS.



Art. 053

— cm. 9 x 5 x 4,4h
Mangiatoia Parma
Parma feeder
Comedero Parma
Mangeoire Parma



8 033844 760634



48 PCS.



Art. 054

— cm. 9 x 5 x 4,4h
Mangiatoia Parma c/ferri
Parma feeder with irons
Comedero Parma con alambres
Mangeoire Parma avec crochet en fer



8 033844 760641



48 PCS.



Art. 022

— cm. 8 x 4 x 3h
Mangiatoia piccola c/ferri
Small feeder with irons
Comedero pequeño con gancho
Mangeoire petit avec crochet



8 033844 760290



100 PCS.



Art. 022/G

— cm. 8 x 4 x 3h
Mang. piccola c/ferri con griglia
Small feeder with irons and grid
Comedero pequeño c/alambres y huella
Mangeoire petit avec crochet et grille



8 033844 762911



100 PCS.



Art. 125

— cm. 8 x 4 x 3h
Mangiatoia piccola g/plastica
Small feeder with plastic hooks
Comedero pequeño con ganchos plastico
Mangeoire petit avec crochet de plastique



8 033844 761257



100 PCS.



Art. 125/G

— cm. 8 x 4 x 3h
Mangiatoia piccola g/plastica e griglia
Small feeder w/plastic hooks and grid
Comedero pequeño c/ganchos plastico y rejilla
Mangeoire petit a/crochet de plastique et grille



8 033844 763666



100 PCS.



Art. 127

— cm. 9 x 7 x 6,5h
 Mangiatoia pappagallo g/plastica
 Parrot feeder with plastic hooks
 Comedero papagayo con ganchos plastico
 Mangeoire perroquet avec crochet de plastique



Art. 015

— cm. 9 x 7 x 6,5h
 Mangiatoia pappagallo c/ferri
 Parrot feeder with irons
 Comedero papagayo con alambres
 Mangeoire perroquet avec crochet



Art. 029

— cm. 8 x 4,5 x 3h
 Mangiatoia piccola rett. c/ferri
 Small rectangular feeder with irons
 Comedero rect. pequeño
 con alambres
 Petit Mangeoire rectangulaire
 avec fers



Art. 032

— cm. 10 x 4,5 x 3h
 Mangiatoia rett. media c/ferri
 Medium rectangular feeder with irons
 Comedero rect.
 medio con alambres
 Moyen Mangeoire rectangulaire
 avec crochet

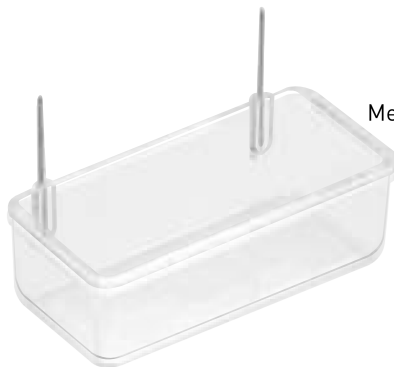

Art. 045

— cm. 10,5 x 5 x 3,5h
 Mangiatoia media c/ferri
 Medium feeder with irons
 Comedero mediano con alambres
 Moyenne mangeoire avec fers



Art. 043

— cm. 10 x 4,5 x 3h
 Mangiatoia pappagallo con alette
 Parrot feeder with wings
 Comedero para papagayo con alas
 Mangeoire pour perroquet avec ailes

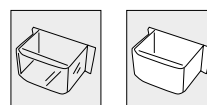



Art. 313

— cm. 7,5 x 5,5 x 4h
 Mangiatoia Olanda c/ganci plastica
 Netherlands Feeder w/plastic hooks
 Comedero Holanda c/ganchos plastico
 Mangeoire Hollande avec crochet plastique



Art. 320

— cm. 7,5 x 5,5 x 0,5h
 Antispreco per art. 313/314
 Non-waste cover for art. 313/314
 Anti-derroche art. 313/314
 Anti-gaspillage art. 313/314



Art. 314

— cm. 7,5 x 5,5 x 4h
 Mangiatoia Olanda c/ganci in ferro
 Netherlands Feeder w/iron hooks
 Comedero Holanda c/ganchos hierro
 Mangeoire Hollande avec crochet de fer



Art. 324

— cm. 7 x 7 x 3h
 Mangiatoia per svezzamento
 Weaning feeder
 Comedero para des
 Mangeoire pour sev



Art. 003

— cm. 18 x 4 x 3h
 Mangiatoia ganci plastica
 Feeders with plastic hooks
 Comedero gancho plastico
 Mangeoire avec crochet plastique

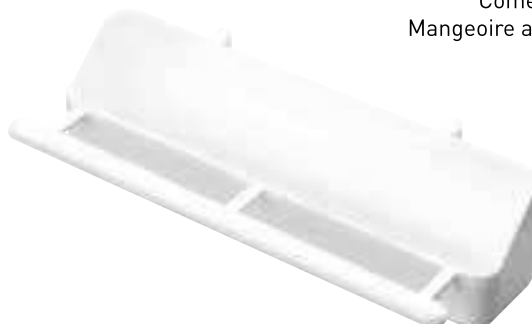

Art. 025/G

— cm. 20 x 6 x 4h

Mangiatoia universale con griglia

Universal feeder with grid

Comedero universal con rejilla

Mangeoire universel avec grille



40 PCS.



8 033844 760344

Art. 051

— cm. 30 x 5,5 x 4h

Mangiatoia Reggio

Reggio feeder

Comedero Reggio

Mangeoire Reggio



30 PCS.



8 033844 760610

Art. 052

— cm. 30 x 5,5 x 4h

Mangiatoia Reggio c/ferri

Reggio feeder with irons

Comedero Reggio con alambres

Mangeoire Reggio avec crochet



30 PCS.

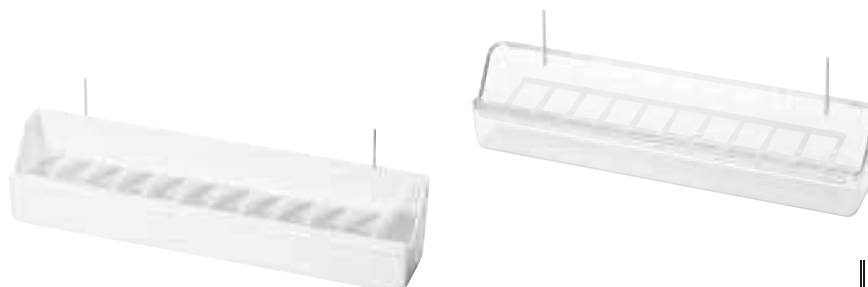

8 033844 760627

Art. 100

— cm. 39 x 5,5 x 6,5h

Mangiatoia per voliera trasparente c/ferri

Transparent aviary feeder with irons

Comedero transp. para voladora con alambre

Mangeoire transparent pour voliere



25 PCS.



8 033844 761143



Art. 099

— cm. 39 x 5,5 x 6,5h
 Mangiatoia per voliera trasparente
 Transparent aviary feeder
 Comedero transp. para voladora
 Mangeoire transparent pour voliere



Art. 101

— cm. 39 x 5,5 x 6,5h
 Mangiatoia per voliera bianca c/f
 White aviary feeder with irons
 Comedero bianco para voladora con alambre
 Mangeoire blanc pour voliere avec crochet

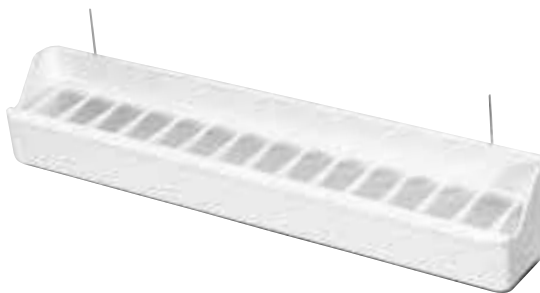

Art. 098

— cm. 39 x 5,5 x 6,5h
 Mangiatoia per voliera bianca
 White aviary feeder
 Comedero blanco para voladora
 Mangeoire blanc pour voliere



Art. 255

— cm. 39 x 5,5 x 6,5h
 Mangiatoia multipla
 Multiple feeder
 Comedero múltiples
 Mangeoire Multiple

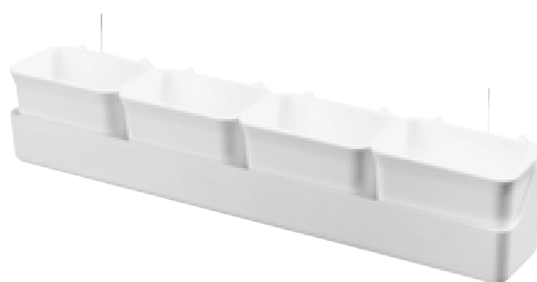

Art. 190

— cm. 23 x 7 x 7,5h
 Mangiatoia Toledo
 Toledo Feeder
 Comedero Toledo
 Mangeoire Toledo



Art. 071

ø cm.7 x 3,5h
Mangiatoia girasole
Sunflower feeder
Comedero Girasol
Mangeoire Tournesol



8 033844 760825



40 PCS.

**Art. 073**

ø cm.7 x 3,5h
Mangiatoia girasole c/base
Sunflower feeder with base
Comedero Girasol con base
Mangeoire Tournesol avec base



8 033844 760849



40 PCS.

Art. 072

— cm. 7 x 12 x 3,5h
Mangiatoia ovale
Oval feeder
Comedero Ovalado
Mangeoire Ovale



8 033844 760832



40 PCS.

**Art. 119**

— cm. 7 x 12 x 3,5h
Mangiatoia Titti
Titti feeder
Comedero Titti
Mangeoire Titti



8 033844 761365



48 PCS.

Art. 094

ø cm.4,5 x 3,5h
Portapastoncino lusso
Luxury mash feeder
Portapasta lujo
Port pâtée



8 033844 761068



100 PCS.

**Art. 094/A**

ø cm. 4,5 x 4,6h
Portapastoncino lusso alto
Luxury high mash feeder
Portapasta lujo alto
Port pâtée luxe haut



8 033844 761075



60 PCS.

Art. 322

ø cm. 2,5 x 2,7 h
Porta Sali Valencia
Cup for salt Valencia
Porta sales Valencia
Port sels Valencia



8 033844 763772



160 PCS.

**Art. 041**

ø cm. 3,5 x 3h
Portasali
Cup for salt
Portasales
Port Sels



8 033844 760504



160 PCS.



Art. 069

ø cm.4 x 3,5h
Portauovo
Egg holder
Portahuevo
Port Oeuf



8 033844 760801

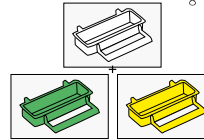
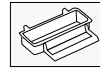

Art. 070

— cm. 9 x 6 x 2h
Portabiscotto
Biscuit holder
Portabizcocho
Port Biscuit



8 033844 760818



Art. 057

— cm. 6 x 2 x 2h
Portamedicinali
Medicine dispenser
Porta medicamentos
Port medicament



8 033844 760672

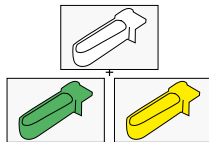

Art. 122

— cm.7,5 x 3 x 6h
Porta verdura e juta
Vegetables/jute holder
Porta verdura y portajuta
Port legume et Jute



8 033844 761396



Art. 033

Portaseppia g/plastica
Sepie holder with plastic hooks
Portaseppia con ganchos plastico
Port Seiche avec crochet



8 033844 760429



Art. 082

Portaseppia
Sepie holder
Portasepia
Port Seiche



8 033844 760931



Art. 142

cm. 5 x 3 x 1,5h
Pinza universale
Universal holder
Pinza universal
Pince Universel



8 033844 761624

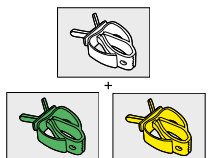

Art. 007

cm. 7 x 3 x 1,5h
Molletta gancio
Peg hook
Pinza sujetaverduras plastico
Pince-crochet



8 033844 760078



Art. 148

Kg.1 - lt. 1
 Comber mangiatoia abbevertoio
 Comber feeder/water dispenser
 Comber comedero/bebedero
 Comber mangeoire/abreuvoir



8 033844 761679

**Art. 149**

Kg.1 - lt. 1
 Comber mangiatoia/beverino da esterno
 External Comber feeder/water dispenser
 Comber comedero/bebedero para externo
 Comber mangeoire/abreuvoir extérieur



8 033844 761686

**Art. 005**

— cm. 31 x 14 x 15h
 Mangiatoia colombi griglia plastica
 Pigeon feeder plastic grid
 Comedero paloma rejilla plastico
 Mangeoire pigeons a/grille de plastique



8 033844 760054

**Art. 006**

— cm. 31 x 14 x 13h
 Mangiatoia colombi griglia ferro
 Pigeon feeder iron grid
 Comedero paloma rejilla hierro
 Mangeoire Pigeons a/grille de fer



8 033844 760061





Art. 049

— cm. 13 x 11 x 13h
Bagno Reggio
Reggio bath
Bañera Reggio
Baignoire Reggio



Art. 318

— cm. 13 x 11 x 13h
Bagno Esterno con ganci in plastica
External Bath with plastic hooks
Bañera Externa con ganchos en plastica
Baignoire exterieur avec crochet en plastique

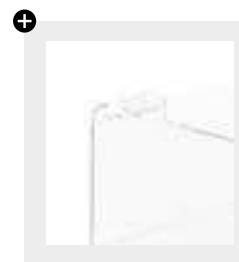

Art. 046

— cm. 13 x 8 x 4h
Vaschetta bagno interna
Internal bathtub
Bañera interna
Baignoire interieur



Art. 074

— cm. 13 x 13 x 13h
Bagno esterno lux
Lux external bath
Bañera externa lujo
Baignoire exterieur luxe

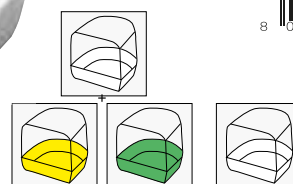
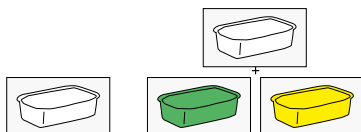

Art. 016

— cm. 10 x 10 x 12h
Bagno esterno a casetta
House-shaped external bath
Bañera externa caseta
Baignoire exterieur maison



Art. 023

— cm. 24 x 16 x 16h
 Bagno esterno grande
 Large external bathtub
 Bañera externa grande
 Baignoire exterieur grand



Art. 023/P

— cm. 24 x 16 x 16h
 Bagno esterno grande c/porte
 Large external bathtub doors
 Bañera externa grande con puerta
 Baignoire exterieur grand avec porte



Art. 027

— cm. 24 x 16 x 19h
 Bagno esterno maxi
 External bathtub maxi
 Bañera externa maxi
 Baignoire exterieur maxi



Art. 027/P

— cm. 24 x 16 x 19h
 Bagno esterno maxi c/porta
 External bathtub maxi with door
 Bañera externa maxi con puerta
 Baignoire exterieur maxi avec porte





Art. 223

— cm. 12 x 13 x 16h
Nido completo estraibile ø 8
Complete extractable nest
ø 8
Nido completo estraibile ø 8



8 033844 762676



Ø8



Art. 224

Ciotola nido
Nest bowl
Cazoleta nido
Bol nid



8 033844 762683

Ø8



Art. 181

— cm. 12 x 12 x 17h
Nido completo estraibile ø 10
Complete extractable nest ø 10
Nido completo estraibile ø 10
Nid complet extractible ø 10



8 033844 762089

Ø10

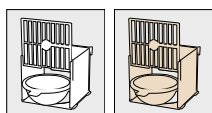

Art. 182

Ciotola nido
Nest cup
Cazoleta nido
Bol nid

Ø10



8 033844 762096



Art. 059

— cm. 12 x 12 x 17h
Nido esterno lusso
External luxury nest
Nido externo lujo
Nid exterieur luxe



8 033844 760696

Ø10

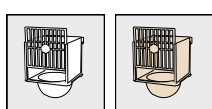

Art. 059/V

— cm. 12 x 12 x 17h
Nido esterno lusso
External luxury nest
Nido externo lujo
Nid exterieur luxe

Ø10



8 033844 760702



Art. 083

— cm. 12 x 13 x 16h
Nido perla
Pearl nest
Nido perla
Nid Perle



8 033844 760948



Art. 084

— cm. 12 x 13 x 16h
Nido diamante
Diamond nest
Nido diamante
Nid Diamant



8 033844 760955



Art. 056

— cm. 10 x 11 x 16h
 Nido esterno ferro/plastica
 Iron/plastic external nest
 Nido externo hierro y plastico
 Nid externe fer/plastique



Art. 039

Nido interno
 Internal nest
 Nido interno
 Nid interne



Art. 008

Nido piccolo
 Small nest
 Nido pequeño
 Petit nid

Ø9



Art. 325

Nido Medio
 Medium Nest
 Nido mediano
 Nid moyen

Ø11



Art. 009

Nido grande
 Large nest
 Nido grande
 Grand nid

Ø12



Art. 136

Ø 10
 Nido ferro
 Iron nest
 Nido hierro
 Nid en fer



Art. 026

Ø 10
 Portanido in ferro
 Iron nest holder
 Portanido hierro
 Porte nid en fer



Art. 063

— cm. 13 x 10 x 9,5h
 Nido per esotico
 Nest for exotic birds
 Nido exotico
 Nid exotique



Art. 063/G

Ganci per nido esotico
 Hooks for exotic nest
 Ganchos para nido exotico
 Crochet pour nid exotique



Art. 299

Nido goccia in vimini
 Drop wicker nest
 Nido gotas en mimbre
 Nid goutte en osier



**Art. 290/8**

Fondello Nido in vimini d.8
 Wicker bird nest d. 8
 Fondo para nido en mimbre d. 8
 Fond nid osier d. 8

**Art. 290/9**

Fondello Nido in vimini d.9
 Wicker bird nest d. 9
 Fondo para nido en mimbre d. 9
 Fond nid osier d. 9

**Art. 290/10**

Fondello Nido in vimini d.10
 Wicker bird nest d. 10
 Fondo para nido en mimbre d. 10
 Fond nid osier d. 10

**Art. 290/11**

Fondello Nido in vimini d.11
 Wicker bird nest d. 11
 Fondo para nido en mimbre d. 11
 Fond nid osier d. 11

**Art. 290/12**

Fondello Nido in vimini d.12
 Wicker bird nest d. 12
 Fondo para nido en mimbre d. 12
 Fond nid osier d. 12

**Art. 290/15**

Fondello Nido in vimini d.15
 Wicker bird nest d. 15
 Fondo para nido en mimbre d. 15
 Fond nid osier d. 15



Art. 291

Fondello Nido in juta d. 8 / 10 / 12
 Bird nest pad in juta d. 8 / 10 / 12
 Fondo para nido en yute d. 8 / 10 / 12
 Fond nid en jute d. 8 / 10 / 12



Art. 292

Fondello Nido in juta - cotone d. 8 / 10 / 12
 Wicker and pad bird nest d. 8 / 10 / 12
 Fondo para nido en yute y mimbre d. 8 / 10 / 12
 Fond nid en jute et coton d. 8 / 10 / 12



Art. 293

Fondello Nido in Poliestere d. 10
 Polyester nest d.10
 Fondo para nido en poliester d.10
 Fond nid polyester d. 10



Art. 306

Anelli in plastica monocolor e multicolore d. 3mm
 Single colour and multicolored plastic rings d. 3 mm
 Anillas en plástico mono color y multicolor d. 3 mm
 Anneaux de plastique monochrome et multicolored. 3 mm



Art. 307

Anelli "click" in plastica d. 8 / 12 / 16
 Plastic "click" rings d. 8 / 12 / 16
 Anillas abierta en plastica d. 8 / 12 / 16
 Anneaux de plastique d. 8 / 12 / 16



Art. 308

Anelli in alluminio d. 2,5 / 3 / 4
 Aluminium rings d. 2,5 / 3 / 4
 Anillas en aluminio d. 2,5 / 3 / 4
 Anneaux de aluminium d. 2,5 / 3 / 4



Art. 308

Anelli in alluminio d. 6 / 8 / 10 / 12
 Aluminium rings d. 6 / 8 / 10 / 12
 Anillas en aluminio d. 6 / 8 / 10 / 12
 Anneaux de aluminium d. 6 / 8 / 10 / 12



Art. 309

Tronchese inox per anellini
 Stainless steel nippers for rings
 Tijeras en acero para anillitas
 Cutter pour anneaux





GABBIE COVA PIEGHEVOLI

FOLDABLE BREEDING CAGES - JAULAS DE CRIA PLEGABLE - CAGES PLIABLE D'ELEVAGE

Art. 316/B

Gabbia cova con laterali plastica
Breeding cage with plastic side
Jaula de cria con laterales plastico
Cage de élevage avec latéral plasti-



8 033844 763536



DA 55
CM



cm. 55 x 30 x 31h

Art. 316/Z

Gabbia cova con laterali plastica zincata
Breeding galvanized cage with plastic side
Jaula de cria con laterales plastico zin-
cada



8 033844 763642



cm. 78 x 60 x 29h



84 pcs



SALVA
SPAZIO

COMPONENTI
DA 55**Art. 036**

— cm. 29,5 x 32 x 1

Laterale in plastica per gabbia cova 55

Plastic side for breeding cage 55

Lateral en plastico para jaula de cria 55

Lateral en plastique pour cage d'élevage 55



8 033844 763301



1 PCS.

**Art. 037/A**

— cm. 54,5 x 6 x 0,5

Bandina frontale gabbia cova 55

Drawer's cover for breeding cage 55

Frontal para bandeja jaula de cria 55

Couverture du tiroir pour cage d'élevage 55



8 033844 764021



1 PCS.

Art. 064

— cm. 54,2 x 30 x 4

Fondo gabbia cova 55

Bottom part of breeding cage 55

Bandeja para jaula de cria 55

Tiroir pour cage d'élevage 55



8 033844 764014



1 PCS.

**Art. 319**

Griglia per gabbia cova 55

Grill for breeding cage 55

Rejilla para jaula de cria 55

Grille pour cage d'élevage 55



8 033844 763567



1 PCS.

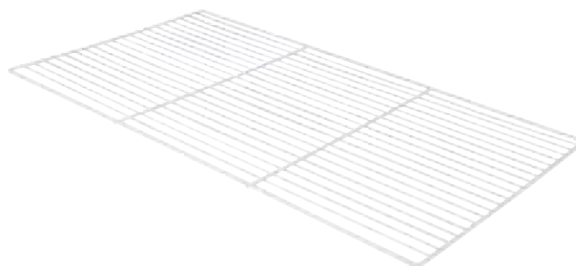



Art. 317/B

Gabbia cova
Breeding cage
Jaula de cria
Cage de élevage



8 033844 763659



**DA 58
CM**

3 PORTE GRANDI

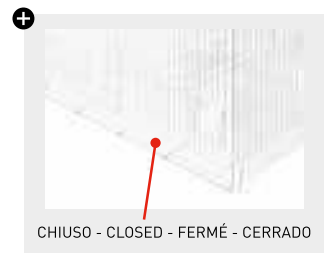

Art. 317/Z

Gabbia cova zincata
Breeding galvanized cage
Jaula de cria zincada
Cage de élevage zingué



8 033844 763543

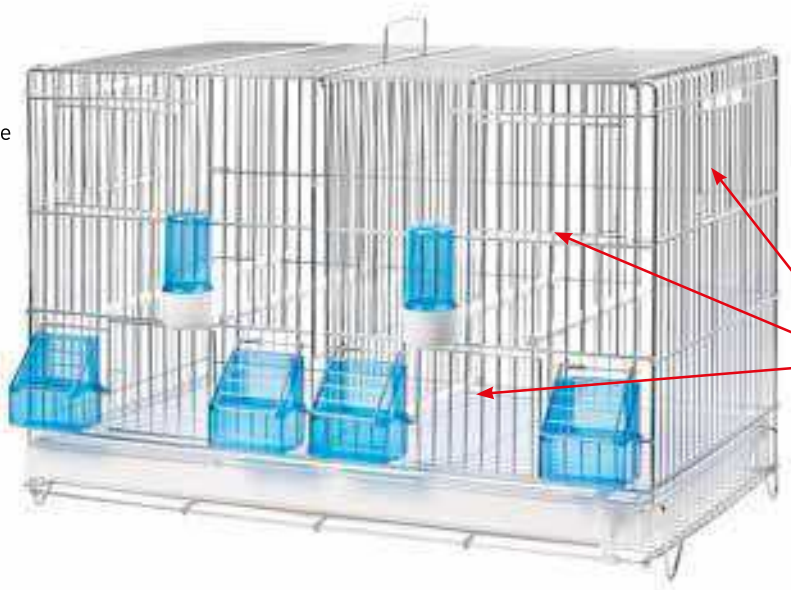

cm. 58 x 30 x 36h

3 PORTE GRANDI



cm. 78 x 60 x 21h



120 pcs

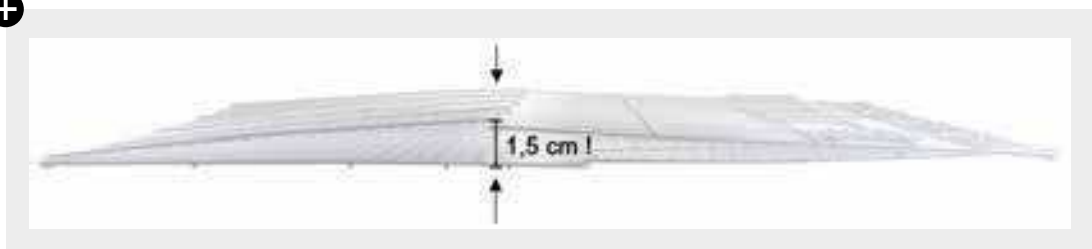

**SALVA
SPAZIO**

Art. 326/B

Gabbia cova
Breeding cage
Jaula de cria
Cage de élevage



**DA 58
CM**



Art. 326/Z

Gabbia cova zincata
Breeding galvanized cage
Jaula de cria zincada
Cage de élevage zingué



cm. 58 x 30 x 36h



cm. 78 x 60 x 21h



120 pcs



**SALVA
SPAZIO**



Art. 326/SC

Gabbia cova
Breeding cage
Jaula de cria
Cage de élevage



**DA 58
CM**



SISTEMA CARTA - PAPER SYSTEM
SISTEMA PAPEL - SYSTEME PAPIER



**COMPONENTI
DA 58**



Art. 375

- cm. 58x37
Parete retro gabbia cova cm 58
Back wall for breeding cage cm 58
Pared trasera para jaula de cria cm 58
Mur d'arrière pour cage d'élevage cm 58

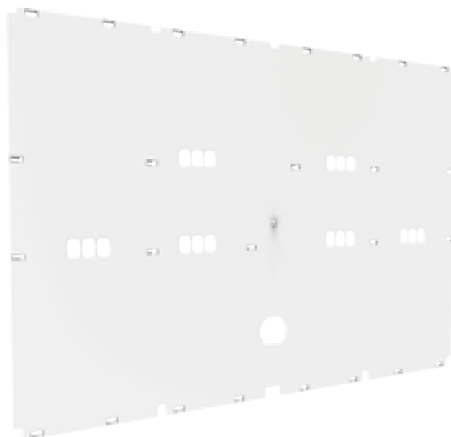

SISTEMA VOLIERA - AVIARY SYSTEM - SISTEMA AVIARIO - SYSTEME VOLIERE

Art. 337

Sistema Voliera
Aviary System
Sistema voladora
Système Volière



8 033844 763918



Art. 356

Gancio per unione gabbie cm 58
Union hook for cage cm 58
Gancho de union jaula cm 58
Crochet pour union cage cm 58



Art. 327

— cm. 31 x 39 x 2,5
Laterale in plastica per gabbia cova 58
Plastic side for breeding cage 58
Lateral en plastique para jaula de cria 58
Lateral en plastique pour cage d'élevage



8 033844 763710



Art. 328

— cm. 56,5 x 30 x 3
Cassetto per gabbia cova 58
Drawer for breeding cage 58
Bandeja jaula de cria 58
Tiroir pour cage d'élevage 58



8 033844 763819





Art. 331

Divisorio chiuso per gabbia cova 58
Closed dividing wall for breeding cage 58
Pared divisoria cerrada para jaula de cria 58
Cloison ferme pour cage d'elevage 58



8 033844 763840



Art. 330

— cm. 32 x 2 x 1
Guida per divisorio
Slide guide for dividing wall
Guia para pared divisoria
Guide pour coison



8 033844 763833



Art. 332

Griglia per gabbia cova 58
Grill for breeding cage 58
Rejilla para jaula de cria 58
Grille pour cage d'elevage 58



8 033844 763857

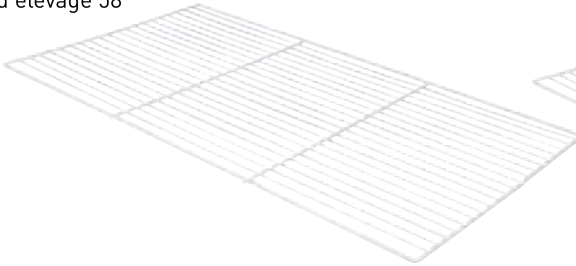

Art. 333

Griglia incurvata per gabbia cova 58
Curved grill for breeding cage 58
Rejilla incurvada para jaula de cria 58
Grille incurvee pour cage d'elevage 58



8 033844 763864

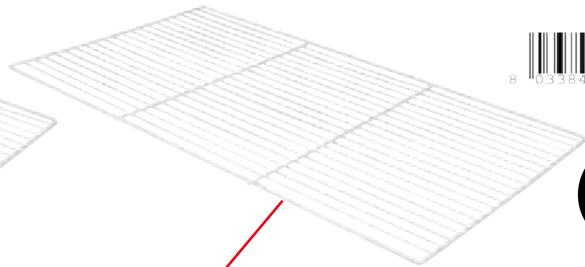

Art. 350

- cm. 31,6
Posatoio per gabbia da cova
Perch for breeding cage
Posadero para jaula de cria
Perche pour cage d'elevage



8 033844 764007

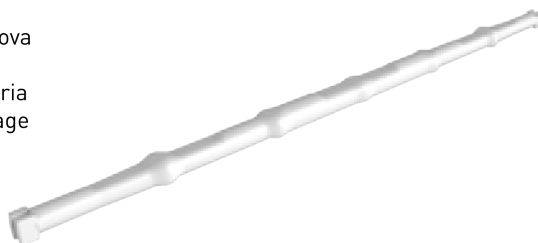

COMPATIBILE CON GABBIE COVA DA 55 CM E 58 CM
COMPATIBLE WITH BREEDING CAGES CM 55 AND CM 58
COMPATIBLE CON JAULA DE CRIA CM 55 Y CM 58
COMPATIBLE AVEC CAGES D'ELEVAGE 55 CM ET 58

Art. 334

Gancio ferma griglia
Grill's block
Bloc du grille
Bloque para rejilla



8 033844 763994

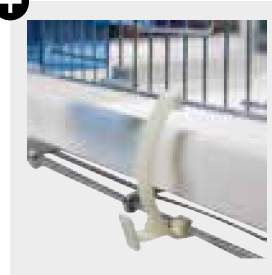

TELAI GABBIE COVA DA 58 CM - STRUCTURE FOR BREEDING CAGES CM 58
ESTRUCTURAS PARA JAULAS DE CRIA CM 58 - STRUCTURE POUR CAGES D'ELEVAGE CM 58

SISTEMA CARTA - PAPER SYSTEM - SISTEMA PAPEL - SYSTEME PAPIER
 FISSAGGIO A MURO - WALL FASTENING - SE FIJA A LA PARED - FIXATION A MUR

Art. 340

Struttura per sistema carta 2 x 4
 Structure for paper system 2 x 4
 Estructura para sistema papel 2 x 4
 Structure pour système papier 2 x4



8 033844 763925

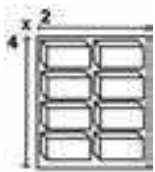

cm. 135 x 41 x 201h



Art. 341

Struttura per sistema carta 4 x 4
 Structure for paper system 4 x 4
 Estructura para sistema papel 4 x 4
 Structure pour système papier 4 x4



8 033844 763932

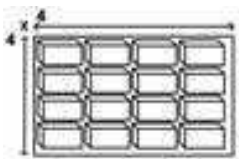

cm. 255 x 41 x 201h



GUIDE PER SOSTENERE LE GABBIE





SISTEMA CON CASSETTO - DRAWER'S SYSTEM - SISTEMA CON BANDEJA - SYSTEM AVEC TIROIR
FISSAGGIO A MURO - WALL FASTENING - SE FIJA A LA PARED - FIXATION A MUR

Art. 342

Strutt. per sistema cassetto 2 x 4
Struct. for drawer's system 2 x 4
Estructura para sistema bandeja 2 x 4
Structure pour système avec tiroir 2 x 4

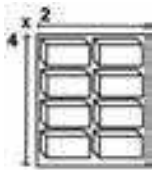

cm. 120 x 41 x 201h



Art. 343

Strutt. per sistema cassetto 4 x 4
Struct. for drawer's system 4 x 4
Estructura para sistema bandeja 4 x 4
Structure pour système avec tiroir 4 x 4

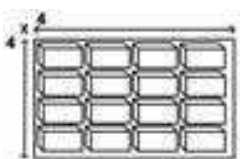

cm. 240 x 41 x 201h



DETTAGLIO DEL RETRO DELLE STRUTTURE

STRUTTURA DOPPIA - DOUBLE STRUCTURE - ESTRUCTURA DOBLE - STRUCTRE DOUBLE

SISTEMA CARTA - PAPER SYSTEM - SISTEMA PAPEL - SYSTEME PAPIER

Art. 345

Struttura doppia per sistema carta 2 x 4
 Double structure for paper system 2 x 4
 Estructura doble para sistema papel 2 x 4
 Structure double pour système papier 2 x 4



8 033844 763970

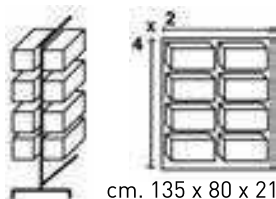

cm. 135 x 80 x 215h



16 GABBIE

Art. 346

Struttura doppia per sistema carta 4 x 4
 Double structure for paper system 4 x 4
 Estructura doble para sistema papel 4 x 4
 Structure double pour système papier 4 x 4



8 033844 764113

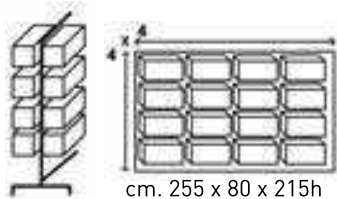

cm. 255 x 80 x 215h



32 GABBIE

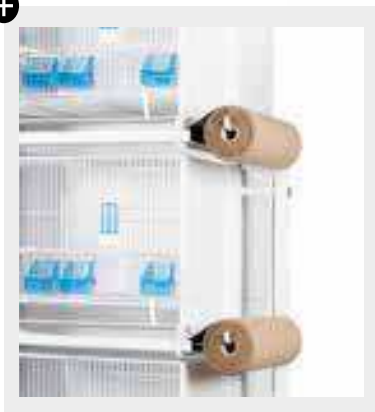



SISTEMA CON CASSETTO - DRAWER'S SYSTEM - SISTEMA CON BANDEJA - SYSTEM AVEC TIROIR

Art. 347

Struttura doppia per sistema cassetto 2 x 4
Double structure for drawer's system 2 x 4
Estructura doble para sistema bandeja 2 x 4
Structure double pour système avec tiroir 2 x4

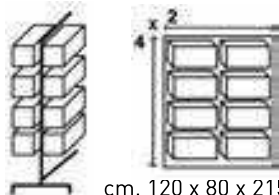

cm. 120 x 80 x 215h



16 GABBIE

Art. 348

Struttura doppia per sistema cassetto 4 x 4
Double structure for drawer's system 4 x 4
Estructura doble para sistema bandeja 4 x 4
Structure pour système avec tiroir 4 x4

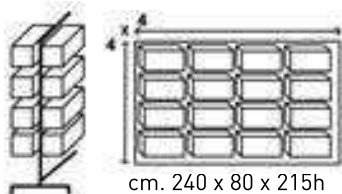

cm. 240 x 80 x 215h



32 GABBIE



COMPONENTI

Art. 344

Ruote per struttura singola art. 340-342
 Wheels for single structure art. 340-342
 Ruedas estructura individual art. 340-342
 Roues pour structure individuel art. 340-342

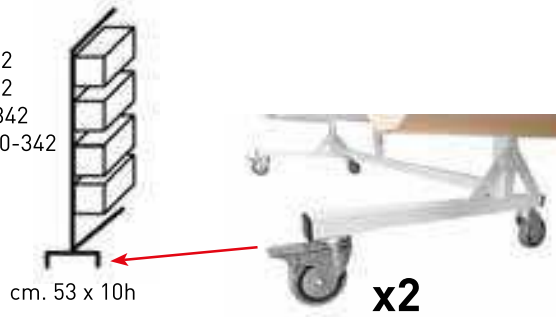

+



Art. 344/G

Ruote per struttura singola art. 341-343
 Wheels for single structure art. 341-343
 Ruedas estructura individual art. 341-341
 Roues pour structure individuel art. 341-343

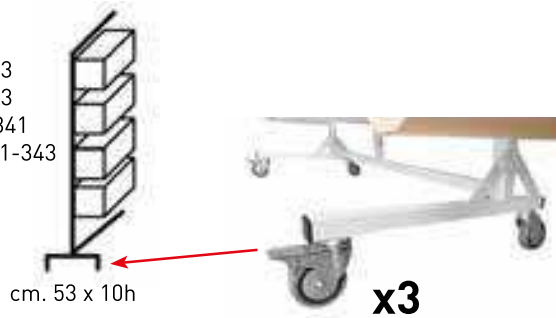

Art. 349

- Ø 12 x 33 cm
 Rotolo di carta
 Paper roll
 Rollo de papel
 Rouleau de papier



+





GABBIE DA ESPOSIZIONE - EXPOSITION CAGES - JAULAS EXPOSICION - CAGE EXPOSITION

IDEALE PER LE MOSTRE - PERFECT FOR SHOWS - PERFECTO PARA MUESTRAS - PARFAIT POUR MONTRE

Art. 315/FB1

cm. 36 x 17 x 30h
Gabbia espos. 1 porta frontale bianco
Exposition cage 1 door white frontal
Jaula exposicion 1 puerta y frontal blanco

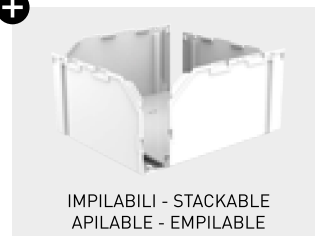

IMPILABILI - STACKABLE
APILABLE - EMPILABLE



Art. 315/FN1

cm. 36 x 17 x 30h
Gabbia espos. 1 porta frontale nero
Exposition cage 1 door black frontal
Jaula exposicion 1 puerta y frontal negro
Cage exposition 1 porte frontal noir



PADELLA - DRAWER - BANDEJA - TIROIR



Art. 315/SP

cm. 36 x 17 x 30h
Gabbia espos. con foro laterale
Exposition cage with lateral hole
Jaula exposicion con agujero lateral
Cage exposition avec trou lateral



SPECIALE CON FORO LATERALE



IDEALE PER LA PREPARAZIONE - PERFECT FOR PREPARATION
PERFECTO PARA LA PREPARACION - PARFAIT POUR LA PREPARATION

Art. 315/FN3V

cm. 36 x 17 x 30h
Gabbia espos. verde 3 porte front. nero
Green exposition cage 3 door black frontal
Jaula exposicion verde 3 puertas y frontal negro



cm. 58 x 39 x 39h



160 pcs



Art. 315/FB3

cm. 36 x 17 x 30h

Gabbia espos. 3 porte frontale bianco

Exposition cage 3 doors white frontal

Jaula exposicion 3 puertas y frontal blanco

blanco



RETE + CASSETTO - GRILL + DRAWER
REJILLA + BANDEJA - GRILLE + TIROIR

Art. 315/FB3A

cm. 36 x 17 x 30h

Gabbia espos. 3 porte frontale bianco

Exposition cage 3 doors white frontal

Jaula exposicion 3 puertas y frontal blanco

Cage exposition 3 portes frontal blanc



MANGIATOIE IN POSIZIONE PIÙ ALTA

Art. 315/FN3

cm. 36 x 17 x 30h

Gabbia espos. 3 porte frontale nero

Exposition cage 3 doors black frontal

Jaula exposicion 3 puertas y frontal negro

Cage exposition 3 portes frontal noir

**Art. 315/FZ3**

cm. 36 x 17 x 30h

Gabbia espos. 3 porte e frontale zincato

Exposition cage 3 doors galvanized frontal

Jaula exposicion 3 puertas y frontal zincado

Cage exposition 3 portes frontal zingue





Art. 315/SC

cm. 36 x 17 x 30h

Gabbia espos. 3 porte sistema carta

Exposition cage 3 doors paper system

Jaula exposicion 3 puertas sistema papel

Cage exposition 3 portes système papier



DOPPIA RETE - DOUBLE GRILL
DOUBLE REJILLA - DOUBLE GRILLE

**SISTEMA CARTA - PAPER SYSTEM
SISTEMA PAPEL - SYSTEME PA-**

Art. 315/C

Coperchio per gabbia esposizione art. 315

Cover for exposition cage art. 315

Tapa para jaula de exposicion art. 315

Couvercle pour cage d'exposition art. 315



MONTATO DALL'INTERNO
FIXED FROM INSIDE
FIJADO DESDE EL INTERIOR
FIXE DE L'INTERIEUR

Art. 315/F

Cassetto per gabbia esposizione art. 315

Drawer for exposition cage art. 315

Bandeja para jaula de exposicion art. 315

Tiroir pour cage d'exposition art. 315

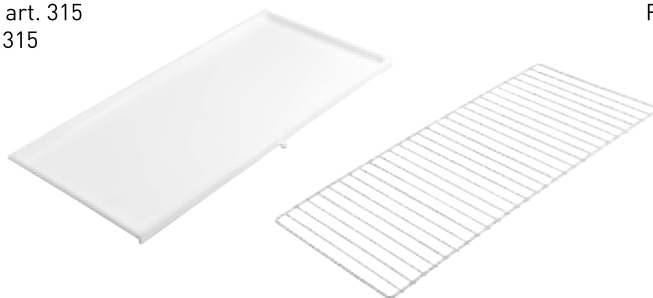

Art. 315/G

Griglia per gabbia esposizione art. 315

Grill for exposition cage art. 315

Rejilla para jaula de exposicion art. 315

Grille pour cage d'exposition art. 315



Art. 315/T

Telaio per gabbia esposizione art. 315

Frame for exposition cage art. 315

Telar para jaula de exposicion art. 315

Cadre pour cage d'exposition art. 315

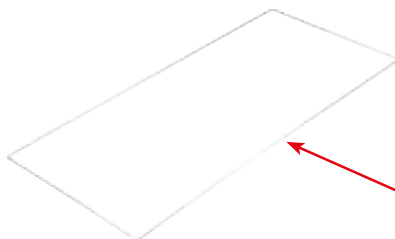

IDEALE PER TRASFORMARE LA GABBIA IN SISTEMA CARTA
IDEAL TO TRASFORM THE CAGE IN PAPER SYSTEM
IDEAL PARA TRANSFORMAR LA JAULA EN SISTEMA PAPEL
IDÉAL POUR TRANSFORMER LA CAGE EN SYSTÈME DE PAPIER

TELAI PER GABBIE DA ESPOSIZIONE - STRUCTURE FOR EXPOSITION CAGES ESTRUCTURAS PARA JAULAS DE EXPOSICION - STRUCTURE POUR CAGE D'EXPOSITION

SISTEMA CARTA - PAPER SYSTEM - SISTEMA PAPEL - SYSTEME PAPIER

Art. 351

Struttura per sistema carta 4 x 5
Structure for paper system 4 x 5
Estructura para sistema papel 4 x 5
Structure pour système papier 4 x 5



8 033844 764052

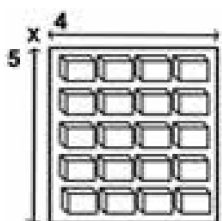

cm. 160 x 22 x 201h



RETRO STRUTTURA

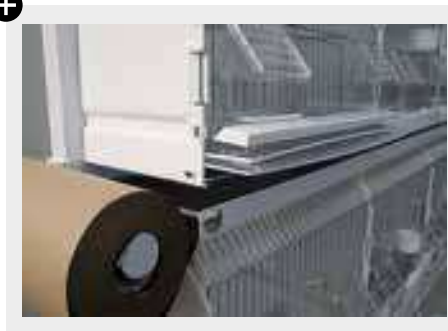

Art. 354

- Ø 10 x 18 cm
Rotolo di carta
Paper roll
Rollo de papel
Rouleau de papier



8 033844 764083





SISTEMA CON PADELLA - DRAWER'S SYSTEM - SISTEMA CON BANDEJA - SYSTEM AVEC TIROIR

Art. 352

Struttura per sistema cassetto 4 x 5
Structure for drawer's system 4 x 5
Estructura para sistema bandeja 4 x 5
Structure pour système avec tiroir 4 x 5

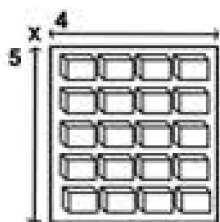

cm. 150 x 22 x 201h

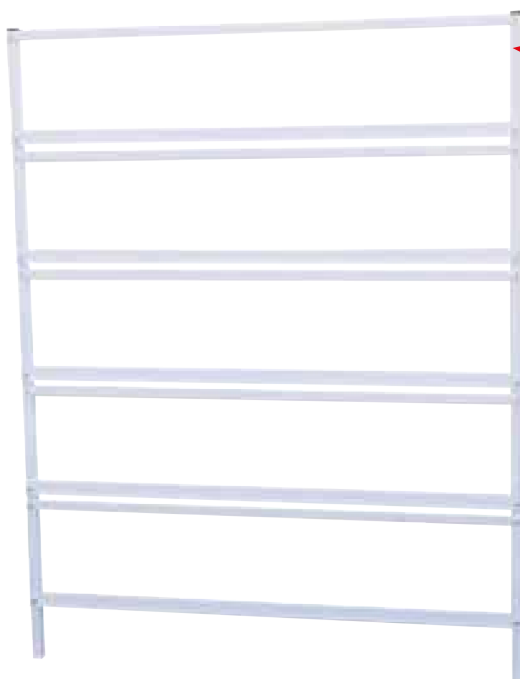

RETRO STRUTTURA



GANCI PER APPENDERE LE GABBIE

Art. 353

Ruote per struttura singola
Wheels for single structure
Ruedas para estructura individual
Roues pour structure individuel

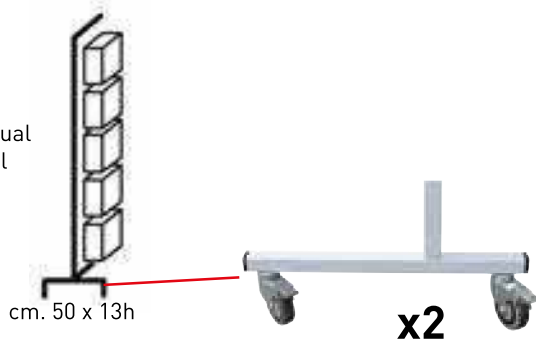

cm. 50 x 13h

x2



Art. 021

— cm. 24 x 16 x 20h
 Gabbia trasportino
 Transport cage
 Jaula transportín
 Cage de transport



8 033844 760283

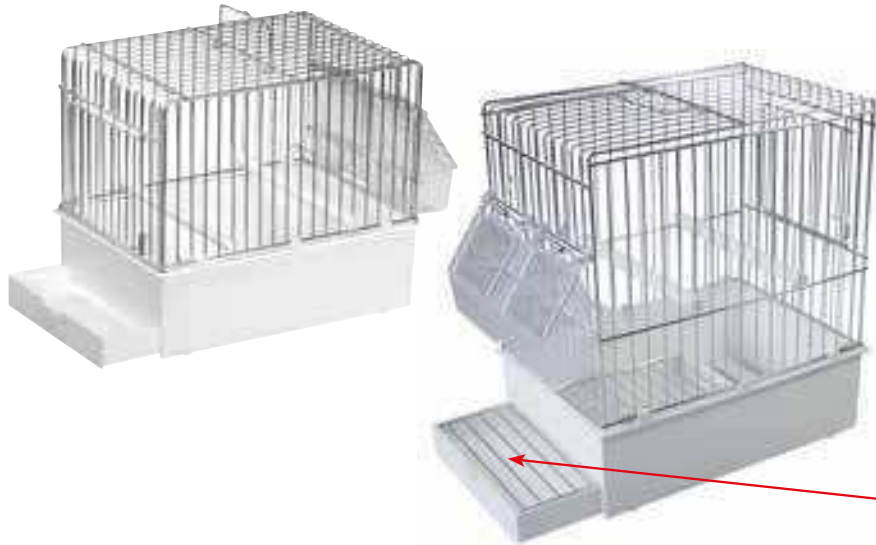

10 PCS.

**Art. 288**

— cm. 24 x 16 x 27,5h
 Gabbia trasportino XL
 Transport cage XL
 Jaula transportín XL
 Cage de transport XL



8 033844 762942



8 PCS.

GRIGLIA INTERNA
 INTERNAL GRILL
 REJILLA INTERNA
 GRILLE INTERIEUR

Art. 020

— cm. 24 x 16 x 20h
 Gabbia Cantori
 Songbird cage
 Jaula canto
 Cage pour oiseaux de chant



8 033844 760276



10 PCS.

**Art. 055**

— cm. 24 x 16 x 19h
 Gabbia per imbecco
 Cage for manual feeding
 Jaula para empapuzar
 Cage pour alimentation



8 033844 760658



10 PCS.

**Art. 019**

— cm. 24 x 16 x 36h
 Gabbia York
 York cage
 Jaula York
 Cage York



6 PCS.



8 033844 760269



Art. 061

— cm. 28 x 20 x 7h
Fondo bengalino
Bengalino bottom
Fondo jaula bengalino
Fond Bengalino

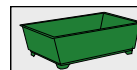
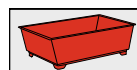
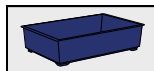
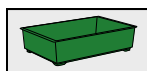
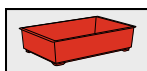

Art. 062

— cm. 31 x 20 x 9h
Fondo jolly
Jolly bottom
Fondo jaula jolly
Fond jolly

Art. 075

— cm. 44 x 27 x 8h
Fondo gabbia cova
Brooding cage bottom
Fondo jaula cria
Fond pour cage de couvée

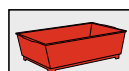
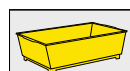
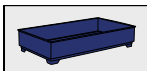
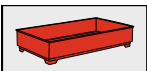
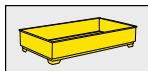

Art. 079

— cm. 38 x 24 x 10,5h
Fondo lusso
Lusso bottom
Fondo jaula lujo
Fond luxe

Art. 095

— cm. 58 x 32 x 9h
Fondo gabbia cova
Brooding cage bottom
Fondo jaula cria
Fond pour cage de couvée

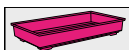
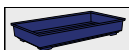
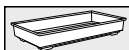

Art. 114

— cm. 67,7 x 35,2 x 12,5h
Fondo cova
Brooding cage bottom
Fondo jaula de cria
Fond pour cage de couvée

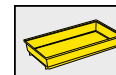
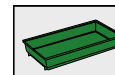
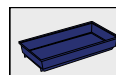
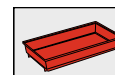

Art. 042

— cm. 3,5 x 1,5
Gancio per fondo gabbia
Hook for cage bottom
Gancho para fondo de jaula
Crochet pour fond de cage



Art. 077

— cm. 5 x 1,5
Gancio fermafondo lungo
Long hook for cage bottom
Gancho largo para fondo jaula
Crochet pour fond de cage



72 ACCESSORI

Art. 001

— cm. 12,5 x 9
Portascheda
Card holder
Portatarjeta
Porte-carte



Art. 001/A

— cm. 12,5 x 9
Scheda a 4 cove
Card for 4 broods
Tarjeta para 4 incubaciones
Carte pour 4 couvées



Art. 001/B

— cm. 12,5 x 9
Scheda a 3 cove
Card for 3 broods
Tarjeta para 3 incubaciones
Carte pour 3 couvées



Art. 091

— cm. 7,5 x 4,5
Etichetta per espositore
Display label
Etiqueta para expositor
Etiquette pour exposant



Art. 104

— cm. 5 x 9
Etichetta por. guinzaglio
Collar display label
Etiqueta para expositor
Etiquette pour exposant





Art. 294

Confezione di Juta
Juta's packaging
Confecion de Yute
Confection de Jute



Art. 297

Cocco-Sisal-Juta-Cotone
Cocco-Sisal-Juta-Cotton
Cocco-Sisal-Yute-Coton
Coque-Sisal-Jute-Coton



Art. 296

Confezione di Filo di Cotone
Cotton's packaging
Confecion de Hilo de coton
Confection de Fil de coton



Art. 295

Juta-Cotone
Juta-Cotton
Yute-Coton
Jute-Coton



Art. 298

Cocco-Sisal-Meliga-Brattea



Art. 118

ø 7,5 x 7h
Porta Juta
Nesting material holder
Porta Juta
Ramasseur de Jute



8 033844 761341

Art. 118/P

Porta Juta pieno
Holder with jute
Porta Juta con juta
Ramasseur de Jute plein



8 033844 761358

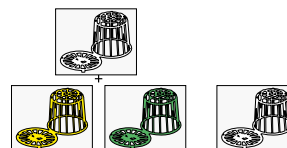
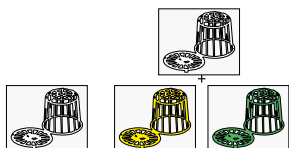

Art. 097

— cm. 6 x 8 X 4h
Raccoglitore universale
Multi purpose holder
Portapelo universal
Ramasseur Universel

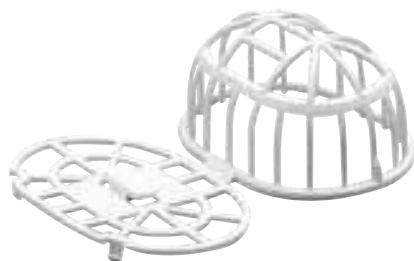

8 033844 761105

Art. 097/P

Raccoglitore juta pieno
Jute holder full
Porta-Juta lleno
Ramasseur de Jute plein



8 033844 761112

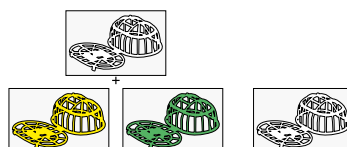
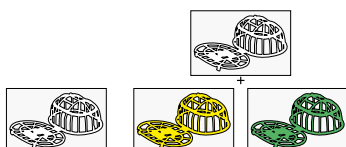

Art. 088

— cm. 6 x 7
 Portina p/g fili verticali
 Door for cage with vertical wires
 Puerta para jaula hierro vertical
 Porte pour grille avec vertical fils



8



24 PCS.

**Art. 089**

— cm. 6 x 7
 Portina p/g fili orizzontali
 Cage door with horizontal wires
 Puerta para jaula hierro horizontal
 Porte pour grille avec horizontal



8



24 PCS.

Art. 135

— cm. 9 x 10
 Altalena
 Swing
 Columpio altalena
 Balançoire

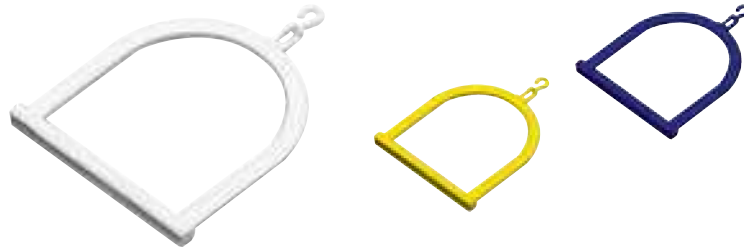

144 PCS.



8

Art. 078

— cm. 15 x 3 x 1h
 Pinza Reggio
 Reggio pliers
 Pinza Reggio
 Pince Reggio



8



24 PCS.

**Art. 010**

ø 1,3 x 1,6h
 Uova piccole
 Small eggs
 Huevo pequeño
 Petit Oeufs



8



100 PCS.

Art. 010/C

ø 1,3 x 1,6h
 Uova piccole colorate
 Small coloured eggs
 Huevo pequeño azul-verde
 Petit Oeufs de couleur



8



100 PCS.

**Art. 011**

ø 3 x 4h
 Uova grandi
 Large eggs
 Huevo grande
 Grand Oeufs



8



100 PCS.

Art. 304

Ø 2 x 2,5h
 Uova medio Parrocchetto
 Medium plastic eggs for parakeets
 Huevos medianos para pericos
 Moyen Oeufs pour perroquet



8



50 PCS.

**Art. 305**

Ø 2,5 x 3h
 Uova grandi Parrocchetto
 Big plastic eggs for parakeets
 Huevos grandes para pericos
 Grand Oeufs pour perroquet



8



50 PCS.

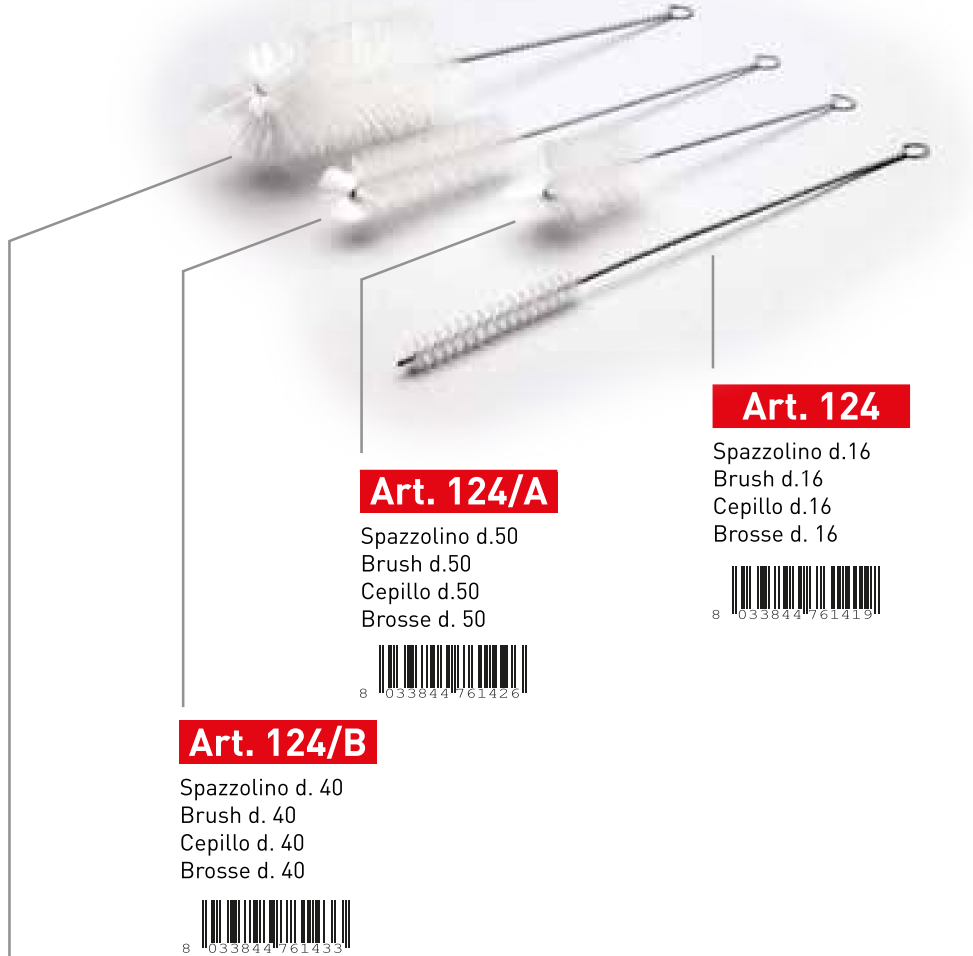

Art. 124

Spazzolino d.16
Brush d.16
Cepillo d.16
Brosse d. 16



8 033844 761419

Art. 124/A

Spazzolino d.50
Brush d.50
Cepillo d.50
Brosse d. 50



8 033844 761426

Art. 124/B

Spazzolino d. 40
Brush d. 40
Cepillo d. 40
Brosse d. 40



8 033844 761433

Art. 124/C

Spazzolino d. 75
Brush d. 75
Cepillo d. 75
Brosse d. 75



8 033844 761440

Art. 113

1 mt.
Paletti trafilati
Drawn perch
Percha trefilada
Perchoir trefilé

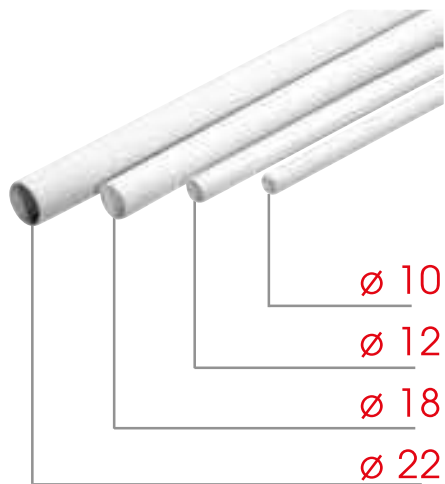

- Ø 10
- Ø 12
- Ø 18
- Ø 22



8 033844 761273



50 PCS.

Art. 050/E

Terminale esterno per posatoio
 External perch ends
 Terminal externo para posador
 Embout exterieur pour perchoir



Ø10 Ø12



Art. 050/I

Terminale per palette
 Perch ends
 Terminal para posador
 Embout perchoir

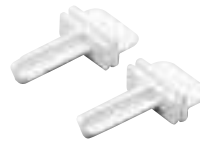

Ø10 Ø12



Art. 085

— cm. 5
 Posatoio plastica
 Plastic perch
 Posador plastico
 Perche plastique



Art. 272

— cm. 16,5
 Posatoio plastica
 Plastic perch
 Posador plastico
 Perche plastique



Art. 081

— cm. 18
 Posatoio
 Perch
 Posador
 Perche

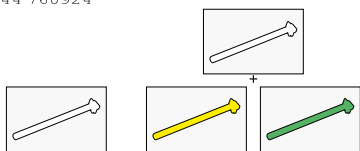

Art. 080

— cm. 22
 Posatoio
 Perch
 Posador
 Perche

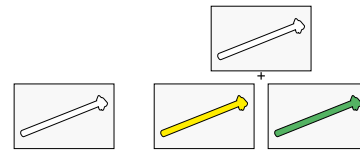

Art. 355

— cm. 11x7,5x32h
 Posatoio Sunset
 Sunset Perch
 Percha Sunset
 Perchoir Sunset





Art. 280

— cm. 44 x 34 x 20h

Maisonette Candy

Candy hamster cage

Jaula para hamster Candy

Cage Hamster Candy



Art. 370

— cm. 52x38x24h

Maisonette Cleo

Cleo hamster cage

Jaula para hamster cleo

Cage pour hamster Cleo



Art. 174

— cm. 50 x 38 x 25h
Maisonette Baby
Hamster cage Baby
Jaula para hamster
Baby



**Art. 150**

— cm. 60 x 40 x 30h

Maisonette
Haster cage
Jaula hamster
Cage rongeurs

**Art. 151**

— cm. 60 x 40 x 30h

Maisonette lusso
Luxury hamster cage
Jaula lujo para hamster
Cage hamster luxe

**Art. 153**

— cm. 60 x 40 x 30h

Maisonette lusso vuota
Empty luxury cage
Jaula lujo vacia
Cage vide de luxe



80 TARTARUGHIERE

Art. 163

— cm. 31,5 x 22 x 7h
Tartarughiera Oasi
Oasis turtle tank
Tortuguera Oasis
Bacs á tortues Oasi



Art. 198

— cm. 40 x 27 x 9,5h
Tartarughiera Oasi Maxi
Oasis Maxi turtle tank
Tortuguera Oasis Maxi



Art. 183

— cm. 43 x 32 x 9,5h
Tartarughiera Maxi
Maxi turtle tank
Tortuguera Maxi
Bacs á tortues Maxi



Art. 164

— cm. 24,5 x 6,5h
Tartarughiera Laguna
Laguna turtle tank
Tortuguera Laguna
Bacs á tortues Laguna



Art. 312

— cm. 44 x 34 x 12h
Tartarughiera Ischia
Ischia Turtletank
Tortuguera Ischia
Bacs á tortues Ischia



Art. 281

— cm. 44 x 34 x 20h
Tartarughiera Daffy
Daffy turtle tank
Tortuguera Daffy
Bacs á tortues Daffy





Art. 371

— cm. 52x38x24h
Tartarughiera Toby
Turtle tank Toby
Tortuguera Toby
Bacs à tortues Toby



Art. 372

— cm. 52x38x24h
Tartarughiera Sammy
Turtle tank Sammy
Tortuguera Sammy
Bacs à tortues Sammy



Art. 175

— cm. 50 x 38 x 25h
 Tartarughiera Baby
 Small turtle tank
 Tortuguera Baby
 Bacs á tortues Baby



Art. 176

— cm. 50 x 38 x 25h
 Tartarughiera Elba
 Elba turtle tank
 Tortuguera Elba
 Bacs á tortues Elba



Art. 152

— cm. 60 x 40 x 30h
 Tartarughiera
 Turtle tank
 Tortuguera
 Bacs á tortues





Art. 111

cc. 70
Sifone roditori c/ventosa "Gigio"
"Gigio" rodents siphon w/suctions caps
Bebedero roedor "Gigio" c/ventosa
Abreuvoir rongeurs "Gigio"



8 033844 761259



Art. 108

cc. 90
Sifone roditori "Fievel"
"Fievel" rodents siphon
Bebedero roedor "Fievel"
Abreuvoir rongeurs "Fievel"



8 033844 761228



Art. 112

cc. 90
Sifone roditori c/ventosa "Gimmy"
"Gimmy" rodents siphon w/suctions caps
Bebedero roedor "Gimmy" c/ventosa
Abreuvoir rongeurs "Gimmy" a/ventouse



8 033844 761266



Art. 140

cc. 200
Sifone "Cip"
"Cip" siphon
Bebedero "Cip"
Abreuvoir "Cip"



8 033844 761600



Art. 141

cc. 200
Sifone "Ciop"
"Ciop" siphon
Bebedero "Ciop"
Abreuvoir "Ciop"



8 033844 761617



Art. 168

cc. 200
Sifone "Cip" c/ventose
"Cip" siphon w/suction caps
Bebedero "Cip" c/ventosa
Abreuvoir "Cip" a/ventouse



8 033844 761952



Art. 107

cc. 280
Sifone roditori "Jerry"
"Jerry" rodents siphon
Bebedero roedor "Jerry"
Abreuvoir rongeurs "Jerry"



8 033844 761211

**Art. 110**

cc. 280
Sifone roditori c/anello "Bernie"
"Bernie" rodents siphon w/ring
Bebedero roedor "Bernie" c/anilla
Abreuvoir rongeurs "Bernie" a/anneau



8 033844 761242

**Art. 106**

cc. 400
Sifone roditori "Bunny"
"Bunny" rodents siphon
Bebedero roedor "Bunny"
Abreuvoir rongeurs "Bunny"



8 033844 761204

**Art. 109**

cc. 400
Sifone roditori c/anello "Bianca"
"Bianca" rodents siphon w/ring
Bebedero roedor "Bianca" c/anilla
Abreuvoir rongeurs "Bianca" a/anneau



8 033844 761235

**Art. 086**

cc. 90
Sifone criceto
Hamster siphon
Bebedero hamster
Abreuvoir Hamster



8 033844 760979

Art. 165

— cm. 25 x 9 x 16h
 Portafieno
 Hay holder
 Porta heno
 Porteur de foin



8 033844 761921

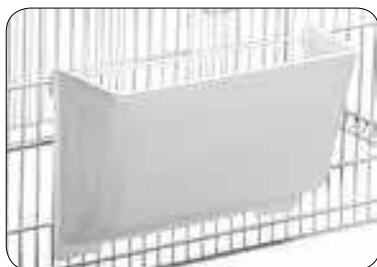

6 PCS.

**Art. 300**

100 g
 Confezione di fibra di cotone per Roditori
 Rodent cotton fibre's packaging
 Confecion de fibra de coton para roedores
 Paquet de fibres de coton pour rongeurs



0,1 KG

Art. 166

Anello con ventosa d. 32 mm
 Ring with suction cap d. 32 mm
 Anillo con ventosa d. 32 mm
 Anneau avec ventouse d. 32 mm



8 033844 761938



10 PCS.

**Art. 167**

Anello doppio con ventosa d. 50 mm
 Double ring with suction cap. d. 50 mm
 Anillo doble con ventosa d. 50 mm
 Anneau avec double ventouse d. 50 mm



8 033844 761945



10 PCS.

Art. 123

— cm. 7 x 3
 Gancio fermafondo universale
 Universal bottom hook
 Gancho universal para fondo
 Universel crochet



50 PCS.



8 033844 761402



Art. 286

— cm. 49 x 33 x 31h

Trasportino Calipso

Calipso transporter

Trasportino Calipso

Cage de transport Calipso



8 033844 763352



Art. 189

— cm. 43 x 26 x 37h
 Trasportino Penelope
 Penelope transporter
 Transportino Penelope
 Cage de transport Penelope



8 033844 762171



Art. 188

— cm. 41 x 54 x 43h
 Lettiera Afrodite
 Afrodite litter
 Lettiera Afrodite
 Litière Afrodite



8 033844 762164





Art. 283

— cm. 44 x 34 x 12h
 Toilette Felix con cornice
 Complete Felix toilet
 Bano Felix con cornisa
 Toilette Felix avec cadre



Art. 138

— cm. 49 x 38 x 14,5h
 Toilette Silvestro completa
 Complete Silvestro toilet
 Toilet Silvestro completa
 Toilette Silvestro avec cadre



Art. 156

— cm. 9 x 25 x 3,5h
 Paletta igienica gatto
 Waste shovel
 Paleta higienica
 Palette hygienique pour chat



Art. 143

— cm. 16 x 40
 Ricambi sac. Snoopy 24 pz.
 Snoopy refill bags 24 pz.
 Recambio bolsa recogedor higienico Snoopy
 Pieces de Rechange pour Snoopy



Art. 357

Ciotola Minou
Bowl Minou
Comedero gato Minou



Lt. 0,2



Art. 358

Ciotola Bizet
Bowl Bizet
Comedero gato Bizet



Lt. 0,3



Art. 359

Ciotola Matisse
Bowl Matisse
Comedero gato Matisse



Lt. 0,5



Art. 360

Ciotola doppia Romeo
Double Bowl Romeo
Comedero doble Romeo



Lt. 0,3 x 2





Art. 162/18

Ciotola
Bowl
Comedero



Lt. 1,5



Art. 162/20

Ciotola
Bowl
Comedero



Lt. 1,2



Art. 162/T

Ciotola tripla
Triple bowl
Comedero tripla



Art. 162/14

Ciotola per Cocker
Cocker Bowl
Comedero para Cocker



Lt. 0,85



Art. 162/24

Ciotola
Bowl
Comedero



Lt. 3,5



Art. 162/26

Ciotola
Bowl
Comedero



Lt. 6



INDICE PER ARTICOLO

CODICE	DESCRIZIONE	PAG.
001	Portascheda	70
001/A	Scheda a 4 cove	70
001/B	Scheda a 3 cove	70
003	Mangiatoia ganci plastica	39
005	Mangiatoia colombi griglia plastica	44
006	Mangiatoia colombi griglia ferro	44
007	Molletta gancio	43
008	Nido piccolo	48
009	Nido grande	48
010	Uova piccole	72
010/C	Uova piccole colorate	72
011	Uova grandi	72
012	Mangiatoia att. dir. piccola	33
013	Mangiatoia att. dir. grande	33
015	Mangiatoia pappagallo c/ferri	38
016	Bagno esterno a casetta	45
017	Mangiatoia Napoli	31
018	Beverino corto	24
018/F	Beverino corto fumè	24
019	Gabbia York	68
020	Gabbia cantori	68
021	Gabbia trasportino	68
022	Mangiatoia piccola c/ ferri	37
022/G	Mangiatoia piccola c/ ferri con griglia	37
023	Bagno esterno grande	46
023/P	Bagno esterno grande c/porte	46
024	Mangiatoia esterna	32
025/G	Mangiatoia universale con griglia	40
026	Portanido in ferro	48
027	Bagno esterno maxi	46
027/P	Bagno esterno maxi c/porta	46
028	Mangiatoia mezzaluna	33
029	Mangiatoia piccola rett. c/ferri	38
030	Sifone lungo mix	24
032	Mangiatoia rett. media c/ferri	38
033	Portaseppia g/plastica	43
034	Sifone Firenze	25
034/F	Sifone Firenze fumè	25
035	Mangiatoia mezzaluna ganci	33
036	Laterale in plastica per gabbia cova 55	52
037/A	Bandina frontale gabbia cova 55	52
038	Sifone lungo	24
039	Nido interno	48
040	Sifone corto mix	24
040/F	Sifone corto mix fumè	24
041	Portasali	42
042	Gancio per fondo gabbia	69
043	Mangiatoia rett. media c/alette	38

CODICE	DESCRIZIONE	PAG.
044	Mangiatoia criceto	83
045	Mangiatoia piccola rett. c/ferri	38
046	Vaschetta bagno interna	45
047	Ruota per criceto	83
049	Bagno Reggio	45
050/I	Terminale per paletto	74
050/E	Terminale esterno per posatoio	74
051	Mangiatoia Reggio	40
052	Mangiatoia Reggio c/ferri	40
053	Mangiatoia Parma	37
054	Mangiatoia Parma c/ ferri	37
055	Gabbia per imbecco	68
056	Nido esterno ferro/pl.	48
057	Portamedicinali	43
058	Sifone per polli	31
059	Nido esterno lusso	47
059/V	Nido esterno lusso	47
060	Sifone Lucca	26
060/A	Sifone Lucca con anello	26
061	Fondo bengalino	69
062	Fondo jolly	69
063	Nido per esotico	48
063/G	Ganci per nido esotico	48
064	Fondo gabbia cova 55	52
065	Sifone mang. pappagalli	30
066	Sifone Napoli	30
066/B	Sifone Napoli basso	30
067	Casetta per criceto	83
068	Sifone Reggio	25
069	Portauovo	43
070	Portabiscotto	43
071	Mangiatoia girasole	42
072	Mangiatoia ovale	42
073	Mangiatoia girasole c/base	42
074	Bagno esterno lux	45
075	Fondo gabbia cova	69
076	Sifone Roma	26
077	Gancio fermafondo lungo	69
078	Pinza Reggio	72
079	Fondo lusso	69
080	Posatoio	74
081	Posatoio	74
082	Portaseppia	43
083	Nido perla	47
084	Nido diamante	47
085	Posatoio plastica	74
086	Sifone criceto	82
087	Sifone banana	26
088	Portina p/g fili verticali	72
089	Portina p/g fili orizzontali	72

CODICE	DESCRIZIONE	PAG.
090	Sifone weekend	27
090/A	Sifone weekend alto	27
090/B	Sifone weekend basso	27
091	Etichetta per espositore	70
092	Sifone weekend Reggio	27
093	Sifone weekend Lucca	27
094	Portapastoncino lusso	42
094/A	Portapastoncino lusso alto	42
095	Fondo gabbia cova	69
097	Raccogliitore universale	71
097/P	Raccogliitore universale pieno	71
098	Mangiatoia per voliera bianca	41
099	Mangiatoia per voliera trasparente	41
100	Mangiatoia per voliera trasparente c/ferri	40
101	Mangiatoia per voliera bianca c/f	41
102	Ruota per criceto chiusa	83
103	Mangiatoia Spagna 2000	33
104	Etichetta por. guinzaglio	70
105	Mangiatoia Italia 2000	33
106	Sifone roditori "Bunny"	82
107	Sifone roditori "Jerry"	82
108	Sifone roditori "Fievel"	81
109	Sifone roditori c/anelli "Bianca"	82
110	Sifone roditori c/anelli "Bernie"	82
111	Sifone roditori c/ventosa "Gigio"	81
112	Sifone roditori c/ventosa "Gimmy"	81
113	Paletti trafilati	73
114	Fondo cova	69
115	Mangiatoia economy	36
115/A	Mangiatoia economy	36
116	Mangiatoia economy	36
116/A	Mangiatoia economy	36
117	Mangiatoia economy plus	36
118	Porta juta	71
118/P	Porta juta pieno	71
119	Mangiatoia Titti	42
122	Porta verdure e juta	43
123	Gancio fermafondi universale	84
124	Spazzolino Ø 16	73
124/A	Spazzolino Ø 50	73
124/B	Spazzolino Ø 40	73
124/C	Spazzolino Ø 75	73
125	Mangiatoia piccola g/plastica	37
125/G	Mangiatoia piccola g/plastica e griglia	37
126	Casetta per criceto	83
127	Mangiatoia pappagallo g/plastica	38
128	Beverino lungo lusso	22
129	Erogatore magic	28
130	Beverino magic	29
131	Sifone Marta	23

CODICE	DESCRIZIONE	PAG.
132	Tabella "Attenti al cane"	86
134	Sifone Firenze lusso	25
135	Altalena	72
136	Nido ferro	48
138	Toilette Silvestro completa	87
140	Sifone "Cip"	81
141	Sifone "Ciop"	81
142	Pinza universale	43
143	Ricambi sac. Snoopy 24 pz.	87
144	Mangiatoia criceto rotonda con base	83
146	Beverino per medicinali	22
147	Mangiatoia "lusso"	32
148	Comber-mangiatoia abbevert.	44
149	Comber-mangiatoia esterno	44
150	Maisonette	77
151	Maisonette lusso	77
152	Tartarughiera	80
153	Maisonette lusso vuota	77
154	Trappola per topi	83
155	Mangiatoia economy dispenser	36
156	Paletta igienica gatto	87
157	Beverino Correggio	25
158	Beverino corto lusso	22
160	Mangiatoia Milano	32
161	Mangiatoia interna Madrid	32
162/14	Ciotola Cocker Lt. 0,85	89
162/18	Ciotola Lt. 1,5	89
162/20	Ciotola Lt. 1,2	89
162/24	Ciotola Lt. 3,5	89
162/26	Ciotola Lt. 6	89
162/T	Ciotola tripla	89
163	Tartarughiera Oasi	78
164	Tartarughiera Laguna	78
165	Portafieno	84
166	Anello con ventosa Ø 32 mm	84
167	Anello doppio con ventosa Ø 50 mm	84
168	Sifone "Cip" c/ventose	81
169	Mangiatoia economy Diamant	36
170	Beverino Aves	29
171	Beverino Aves	29
172	Mangiatoia Ines	37
173	Mangiatoia Dalia	37
174	Maisonette Baby	76
175	Tartarughiera Baby	80
176	Tartarughiera Elba	80
181	Nido completo estraibile Ø 10	47
182	Ciotola nido	47
183	Tartarughiera Maxi	78
184	Sifone Leo	25
185	Mangiatoia Hasselt	31

CODICE	DESCRIZIONE	PAG.
186	Porta	31
188	Lettieria Afrodite	86
189	Trasportino Penelope	86
190	Mangiatoia Toledo	41
198	Tartarughiera Oasi maxi	78
199	Mangiatoia Piacenza	31
200	Trasportino con griglia fissa e mangiatoia esterna	05
201	Trasportino con griglia fissa e mangiatoia interna	06
202	Trasportino con griglia telescopica	07
203	Tino + n. 6 Secondino	10
204	Trasportino per ondulati a 5 posti	08
205	Trasportino per medie taglie a 5 posti	09
206	Beverino rettangolare	18
207	Coperchio con maniglia	05
208	Ruote	19
209	Divisoria per Tino	19
210	Gancio	18
211	Griglia per art. 200	20
212	Griglia per art. 201	20
213	Griglia per art. 202	20
214	Mangiatoia rettangolare	18
215	Parete estraibile per Tino	19
216	Posatoio per art. 200-201-202	18
217	Coperchio per Maxi Tino	09
218	Tino vuoto	06
219	Salva-goccia per art. 129	28
220	Trasportino singolo per taglie fino 14 cm	10
221	Beverino Secondino	22
222	Sifone universale	23
223	Nido completo estraibile Ø 8	47
224	Ciotola nido	47
225	Valigia completa di 10 Secondini	12
226	Valigia vuota	12
227	Parete estraibile per Maxi Tino	19
228/A	Divisoria per Maxi Tino	19
228/C	Divisoria per Maxi Tino	19
229	Griglia per art. 204	21
230	Griglia per art. 205	21
232	Mangiatoia interna con ganci	32
233	Trasportino per trasporto collettivo retro chiuso	09
234	Maxi Tino + n. 10 Secondini	11
235	Tino Economy	04
236	Divisoria per Tino Economy	19
237	Supporti per secondino	19
238	Griglia per art. 235	20
239	Maxi Tino vuoto con supporti	11
240	Beverino Dino	22
242	Trasporto singolo per taglie fino 28 cm	17

CODICE	DESCRIZIONE	PAG.
244	Trasporto singolo per taglie fino 18 cm	13
245	Maxi Tino + n. 5 Secondini maxi	17
247	Gancio per coperchio valigia	18
248	Beverino Secondino maxi	18
249	Posatoio per art. 235	18
250	Interno completo x art. 200	05
251	Interno completo x art. 201	06
252	Interno completo x art. 202	07
253	Mangiatoia "Ara" piccola	30
254	Mangiatoia "Ara" media	30
255	Mangiatoia multipla	41
256	Valigia 6 posti per art. 244	13
257	Valigia 8 posti per art. 244	14
258	Valigia 12 posti per art. 244	14
259	Valigia 18 posti per art. 244	15
260	Carrello con 160 secondini medi	16
261	Valigia vuota 6 posti	13
262	Valigia vuota 8 posti	14
263	Valigia vuota 12 posti	14
264	Valigia vuota 18 posti	15
265	Kit luci per valigia 6 posti	13
266	Kit luci per valigia 8 posti	14
267	Kit luci per valigia 12 posti	14
268	Kit luci per valigia 18 posti	15
269	Kit luci per art. 260	16
270	Kit luci universale	15
271	Accendisigari con cavo di mt. 3	15
272	Posatoio plastica	74
273	Carrello con 60 secondini medi	16
273/A	Modulo superiore con 24 secondini	16
273/B	Modulo inferiore con 36 secondini	16
273/C	Comp. trasformazione ruote removibili	16
274	Sifone Aosta corto	22
275	Sifone Ferrara	23
276	Copertura x valigia 6 posti	13
277	Copertura x valigia 8 posti	14
278	Copertura x valigia 12 posti	14
279	Copertura x valigia 18 posti	15
280	Maisonette Candy	75
281	Tartarughiera Daffy	78
283	Toilette Felix con cornice	87
284	Sifone Aosta lungo	23
285	Sifone Livorno	23
286	Trasportino Calipso	85
288	Gabbia trasportino XL	68
290/8	Fondello nido in vimini Ø 8	49
290/9	Fondello nido in vimini Ø 9	49
290/10	Fondello nido in vimini Ø 10	49
290/11	Fondello nido in vimini Ø 11	49
290/12	Fondello nido in vimini Ø 12	49

CODICE	DESCRIZIONE	PAG.
290/15	Fondello nido in vimini Ø 15	49
291	Fondello nido in juta Ø 8/10/12	50
292	Fondello nido in juta-cotone Ø 8/10/12	50
293	Fondello nido in poliestere Ø 10	50
294	Confezione di juta	71
295	Juta-cotone	71
296	Confezione di filo di cotone	71
297	Cocco-Sisal-Juta-Cotone	71
298	Cocco-Sisal-Meliga-Brattea	71
299	Nido goccia in vimini	48
300	Fibra di cotone per roditori	84
301	Tubo diam. int. 4 per art. 129	28
302	Tubo diam. int. 8 per art. 219	28
303	Raccordo a "T" per tubo art. 301	28
304	Uova medio Parrocchetto	72
305	Uova grandi Parrocchetto	72
306	Anelli in plastica monocolor Ø 3 mm	50
307	Anelli "click" in plastica Ø 8/12/16	50
308	Anelli in alluminio Ø 2,5/3/4/6/8/10/12	50
309	Tronchese inox per anellini	50
310	Beverino Capri	29
311	Beverino Giglio	29
312	Tartarughiera Ischia	78
313	Mangiatoia Olanda c/ganci plastica	39
314	Mangiatoia Olanda c/ganci in ferro	39
315/C	Coperchio per gabbia esp. art. 315	65
315/F	Cassetto per gabbia esp. art. 315	65
315/G	Griglia per gabbia espos. art. 315	65
315/FB1	Gabbia espos. 1p. frontale bianco	63
315/FB3	Gabbia espos. 3p frontale bianco	64
315/FB3A	Gabbia espos. 3p frontale bianco	64
315/FN1	Gabbia espos. 1p.frontale nero	63
315/FN3V	Gabbia espos. verde 3p. frontale nero	63
315/FN3	Gabbia espos. 3p. frontale bianco	64
315/FZ3	Gabbia espos. 3 p. frontale zincato	64
315/SC	Gabbia espos. 3p. sistema carta	65
315/SP	Gabbia espos. c/foro l.	63
315/T	Telaio per gabbia esposizione art. 315	65
316/B	Gabbia cova c/laterali plastica	51
316/Z	Gabbia cova c/laterali plastica zincata	51
317/B	Gabbia cova	53
317/Z	Gabbia cova zincata	53
318	Bagno esterno con ganci in plastica	45
319	Griglia per gabbia cova 55	52
320	Antispreco per art. 313/314	39
321	Sifone Bari	30
322	Porta sali Valencia	42
323	Mangiatoia eclissi	34
323/G	Gancio per attacco universale Mang. Eclissi	35

CODICE	DESCRIZIONE	PAG.
323/I	Supporti attacco interno gabbia Mangiatoia Eclissi	35
324	Mangiatoia per svezamento	39
325	Nido medio	48
326/B	Gabbia cova	54
326/Z	Gabbia cova zincata	54
326/SC	Gabbia cova	55
327	Laterale in plastica per gabbia cova 58	56
328	Cassetto per gabbia cova 58	56
330	Guida per divisorio	57
331	Divisorio chiuso per gabbia cova 58	57
332	Griglia er gabbia cova 58	57
333	Griglia incurvata per gabbia cova 58	57
334	Gancio ferma griglia	57
335	Mangiatoia Amsterdam	31
336	Coperchio per mangiatoia mezzaluna	33
337	Sistema voliera	56
338	Rubinetto per tubo art. 301	28
339	Serbatoio per impianto a goccia	28
340	Struttura per sistema carta 2X4	58
341	Struttura per sistema carta 4X4	58
342	Struttura per sistema cassetto 2X4	59
343	Struttura per sistema cassetto 4X4	59
344	Ruota per struttura singola	62
345	Struttura doppia per sistema carta 2X4	60
346	Struttura doppia per sistema carta 4X4	60
347	Struttura doppia per sistema cassetto 2X4	61
348	Struttura doppia per sistema cassetto 4X4	61
349	Rotolo di carta 12X33	62
350	Posatoio per gabbia da cova	57
351	Struttura per sistema carta 4X5	66
352	Struttura per sistema cassetto 4X5	67
353	Ruote per struttura singola	67
354	Rotolo di carta 12X18	66
355	Posatoio Sunset	74
356	Gancio per unione gabbia cm 58	56
357	Ciotola Minou Lt.0,2	88
358	Ciotola Bizet Lt. 0,3	88
359	Ciotola Matisse Lt. 0,5	88
360	Ciotola doppia Romeo Lt. 0,3x2	88
370	Maisonette Cleo	75
371	Tartarughiera Toby	79
372	Tartarughiera Sammy	79
375	Parete retro per gabbia cova cm 58	55



www.2g-r.com

2 GR di Gobbi Luciano & C. snc

Via Verzelloni, 14 - 42015 Correggio (RE) - Italy
Tel. +39.0522.694935 - Fax +39.0522.631513
www.2g-r.com - info@2g-r.com

